



SPECIFICATION

Surface Acoustic Wave Filter

USER



USER PART No.

SEMCO PART No. **SFWG00DB002**

DOC. No. SMS-51-L-SFT FW-43

DATE July, 30, 2013

REVISION 000

WISOL					
ISSUED BY	Kim, Young-Hun 	APPROVED BY (R&D)	Hong, Seong-Su 	APPROVED BY (QC)	Jeon. Hyeon Cheol 
User					
ISSUED BY		CHECKED BY		APPROVED BY	

WISOL CO., LTD.
373-7, GAJANG-DONG, OSAN-SI,
GYUNGGI-DO, KOREA, 447-210
<http://www.wisol.co.kr>

购买原装正品请认准-德方电子
免费服务热线: 400-655-8700
深圳总部电话: 0755-28187877
网址: www.denovocn.com

▶ **A TABLE OF CONTENTS**

1. REVISION HISTORY	3
2. DEFINITION	4
3. PRECAUTIONS	4
4. OUTLINE DRAWING & DIMENSIONS	5
5. MARKING	6
6. PERFORMANCE	7
6-1. MAXIMUM RATINGS	7
6-2. ELECTRICAL CHARACTERISTICS	8
7. RELIABILITY	11
7-1. ENGINEERING SAMPLE FLOW CHART	11
7-2. TEST ITEM & CONDITION	12
8. REFLOW CONDITION	13
9. RECOMMENDED PCB DIMENSIONS	13
10. CAUTION	14
11. PACKING	15
11-1. DIMENSIONS	15
11-2. REELING QUANTITY	16
11-3. TAPING STRUCTURE	16
11-4. INNER BOX(Reel Packing) STRUCTURE	17
11-5. OUTER BOX STRUCTURE	18
12. TAPE SPECIFICATIONS	19
13. RoHS DATA	20

1. REVISION HISTORY

000	July 30, 2013	All Page	Make specification
-----	---------------	----------	--------------------

2. DEFINITION

2-1. PART No.

SFWG00DB002

① ② ③ ④ ⑤ ⑥

No.	EXPLANATION	
①	SAW Filter	
②	Design Type	
③	Center Frequency Filter1	1900MHz (1880 MHz ~ 1920MHz)
④	Balanced Filter	Input: Unbalanced 50 ohm Output: Unbalanced 50 ohm
⑤	Package size: 1.5×1.1mm ²	
⑥	Design Revision (02 : Molding Type)	

2-2. APPLICATION: TD SCDMA B39, B34 1in2out type Dual Rx Filter. Unbalance type

3. PRECAUTIONS

3-1. This device should not be used in any type of fluid such as water, oil, organic solvent, etc.

3-2. This is a hermetic device.

MSL(Moisture Sensitive Level) is the '2a' level.

3-3. Ultrasonic cleaning shall be avoided.

3-4. Isopropyl Alcohol and Ethyl Alcohol can be used for cleaning. Contact us before using other cleaning solvents than above

3-5. This is an electrostatic sensitive device.

Please avoid static voltage during operation and storage.

3-6. Sudden change of temperature shall be avoided, deterioration of the characteristics can occur.

3-7. If any malfunction due to designing or manufacturing which is out of specification occurs within one year after the products have been delivered, the maker should exchange the defective products.

4. OUTLINE DRAWING & DIMENSIONS

[Unit: mm]

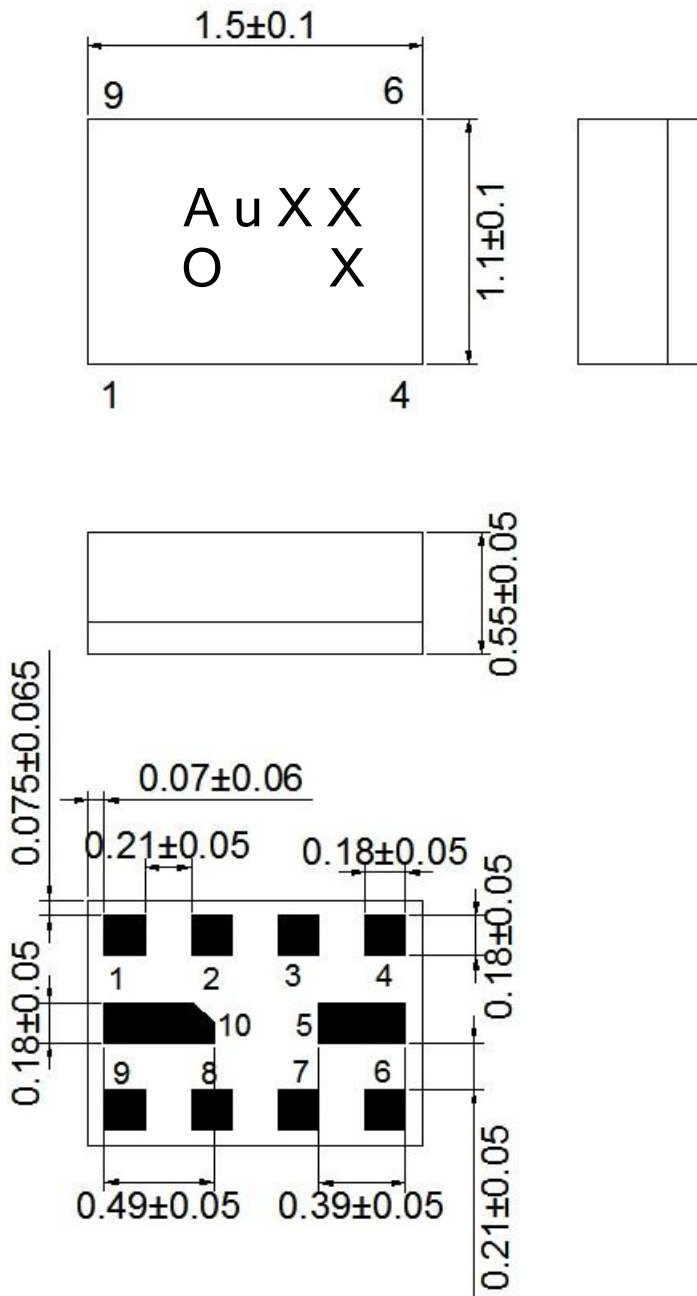

No.	Function
1	TD SCDMA B39 / B34 Input
9	TD SCDMA B39 Output
6	TD SCDMA B34 Output
Others	Ground

5. MARKING



5-1. A u X X X

- The 1st 2nd character 'Au' indicates the model name of SAW Filter SFWG00DB002.
- The 3rd character 'X' indicates the year and the month of manufacture.

Year	Month											
	1	2	3	4	5	6	7	8	9	10	11	12
2013	P	Q	R	S	T	U	V	W	X	Y	Z	a
2014	1	2	3	4	5	6	7	8	9	A	B	C
2015	D	E	F	G	H	I	J	K	L	M	N	O
2016	P	Q	R	S	T	U	V	W	X	Y	Z	a

※ This rotates by the 3 years.

- The 4th, 5th character 'X' indicates Lot No.

5-2. O

- This symbol indicates input pin 1.
- This indicates the producing center
 - : China,

5-3. Marking: Laser Marking

6. PERFORMANCE

6-1. MAXIMUM RATINGS

CHARACTERISTICS	RATINGS	UNITS
DC Permissive Voltage	5	V
Maximum Input Power	15	dBm
Operating Temperature Range	- 30 ~ +85	°C
Storage Temperature Range	- 40 ~ +85	°C

6-2. ELECTRICAL CHARACTERISTICS
6-2-1. TABLE

Ta = - 30 ~ +85℃

ITEM	UNIT	TD SCDMA B39				TD SCDMA B34			
		Freq. Range [MHz]	Min.	Typ. (25℃)	Max.	Freq. Range [MHz]	Min.	Typ. (25℃)	Max.
Insertion Loss	dB	1880~1920	-	1.7	2.3	2010~2025	-	1.9	2.5
Inband Ripple	dB	1880~1920	-	0.8	1.5	2010~2025	-	0.7	1.5
Input VSWR	-	1880~1920	-	1.6	2.3	2010~2025	-	1.4	2.3
Output VSWR	-	1880~1920	-	1.6	2.3	2010~2025	-	1.4	2.3
Absolute Attenuation	dB	1500 ~ 1750	25	30	-	1500 ~ 1750	27	33	-
	dB	1750 ~ 1805	25	29	-	1750 ~ 1805	28	35	-
	dB	1805 ~ 1840	22	29	-	1805 ~ 1850	30	36	-
	dB	2000 ~ 2135	20	24	-	1850 ~ 1950	28	35	-
	dB	2135 ~ 2350	22	27	-	1950 ~ 1970	10	22	-
						2050 ~ 2095	3.5	8	-
						2095~2350	30	35	-
Termination Impedance		Input: Unbal. 50 ohm //shunt 5.6nH Output: Unbal. 50 ohm//serie 1.0nH				Input: Unbal. 50ohm //shunt 5.6nH Output: Unbal. 50 ohm			

6-2-2. TEST FIXTURE

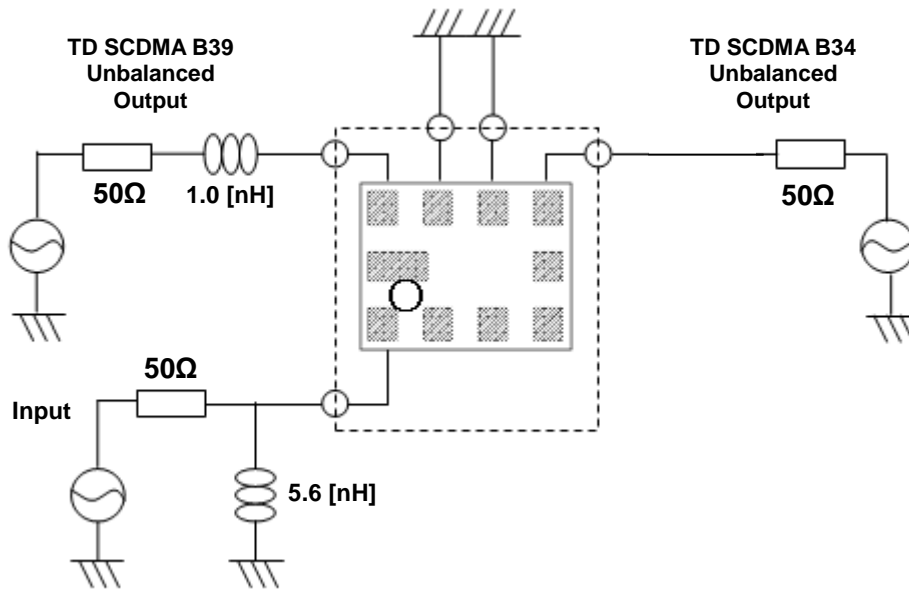

6-2-3. GRAPH

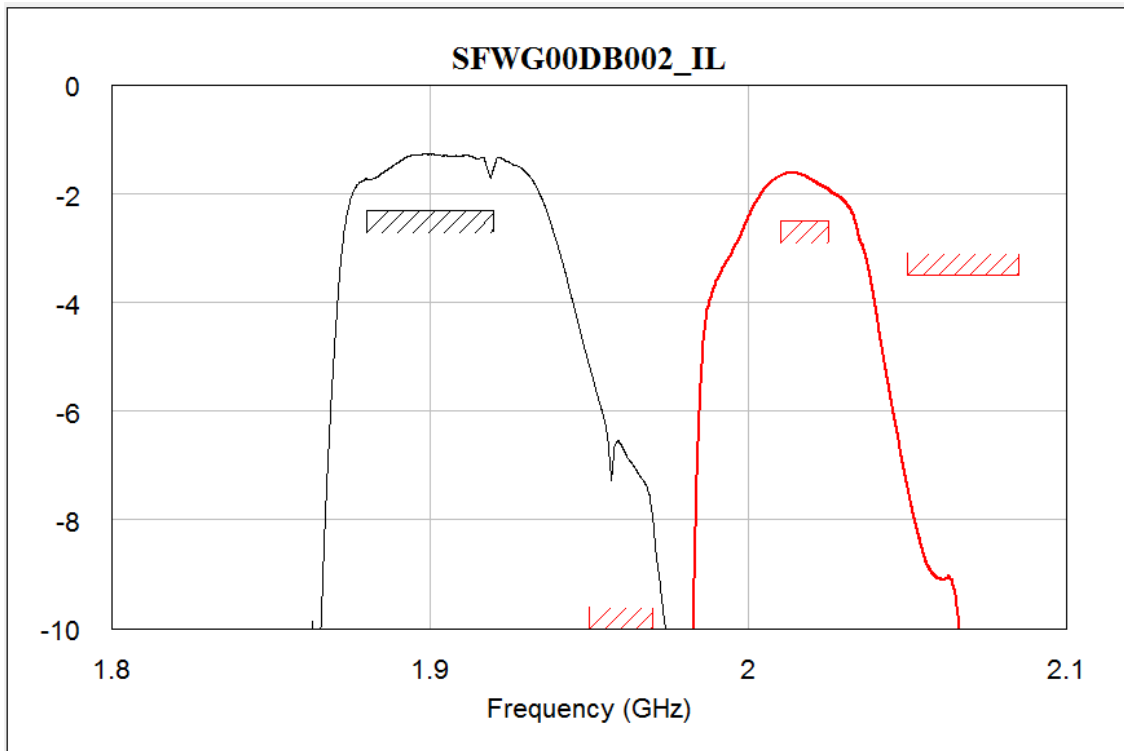
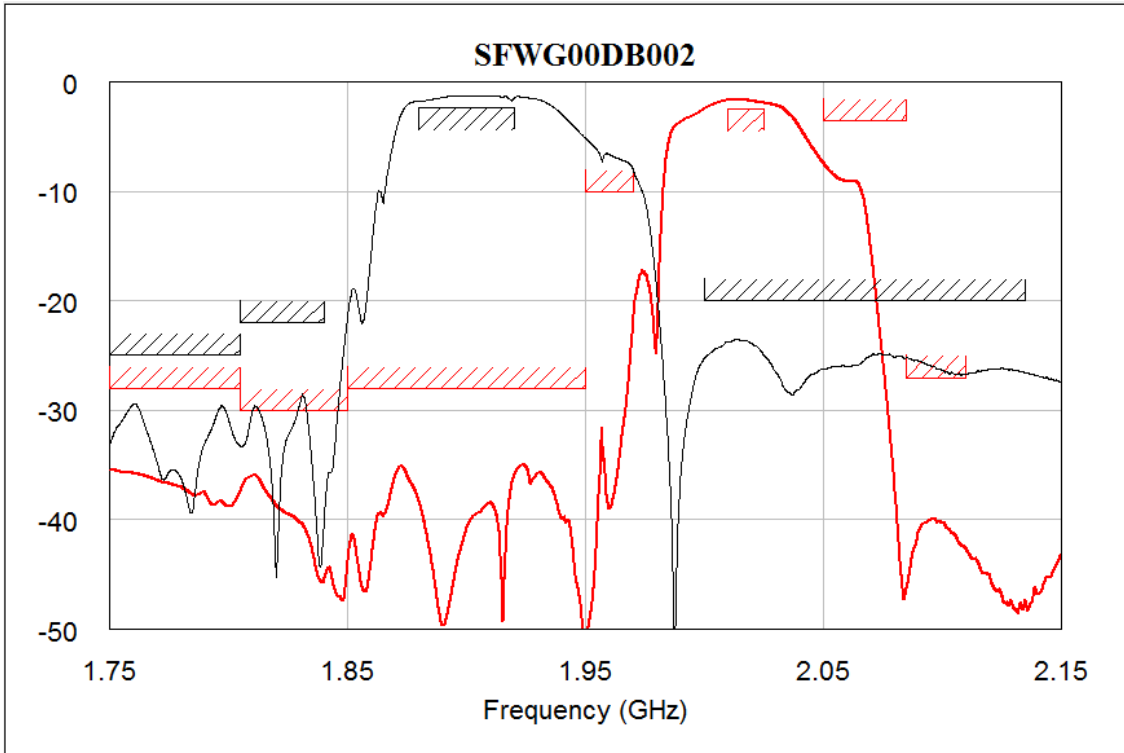

7. RELIABILITY

7-1. ENGINEERING SAMPLE FLOW CHART

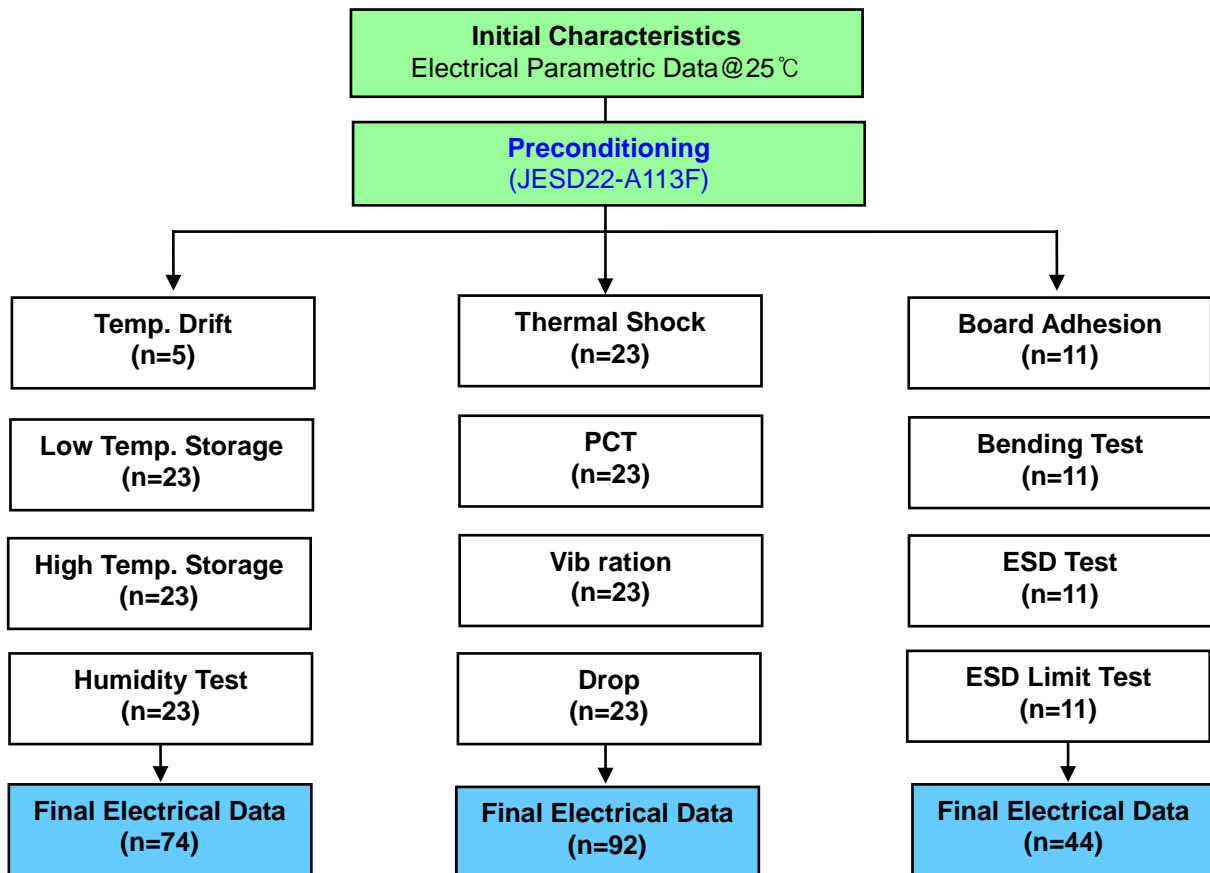

7-2. TEST ITEM & CONDITION

CATEGORY	TEST ITEM	TEST CONDITION	REMARK
	Preconditioning	+125℃ 24hr Baking → +60℃ 60%RH 120hr → Reflow Test(3times)	JESD22A113F



Environment Test	Temp. Drift	-30℃ → +25℃ → +85℃	description
	High Temp. Storage	+85℃ 240hr	JESD22-A103C
	Low Temp. Storage	-40℃ 240hr	JESD22-A119
	High Temp. High Humidity Storage	+85℃ 85%RH 240hr	JESD22-A106B
	Thermal Shock	-40℃/30min ⇔ +85℃/30min , 100cycle	JESD22-A106A
	High Temp. Operating	+121℃ 100%RH 96hr	JESD22-A102C
Mechanical Test	Vibration Test (Random)	20 Hz~2000 Hz,0.053G ² /Hz or 8gs RMS,15min/plane	IEC 68-2-36 Fdb
	Drop Test	152 cm 12times Steel floor JIG(110g~150g)	IEC 1178-1.4.8.9
	Board Adhesion	0.5 mm/sec 1point push	IEC 68-2-21 Ue3
	Bending Test	0.5 mm/sec 3times -PCB : FR4 , PCB SIZE : 100*40 mm	IEC 68-2-21 Ue3
Physical Test	Solder Heat Resistance	±250V,C=100pF,R=1.5 kΩ, 1times	IEC 68-2-21 Ue3
	static marginal test	C=100pF,R=1.5 kΩ, 1times(demand of customer)	JESD22-A114F

8. REFLOW CONDITION

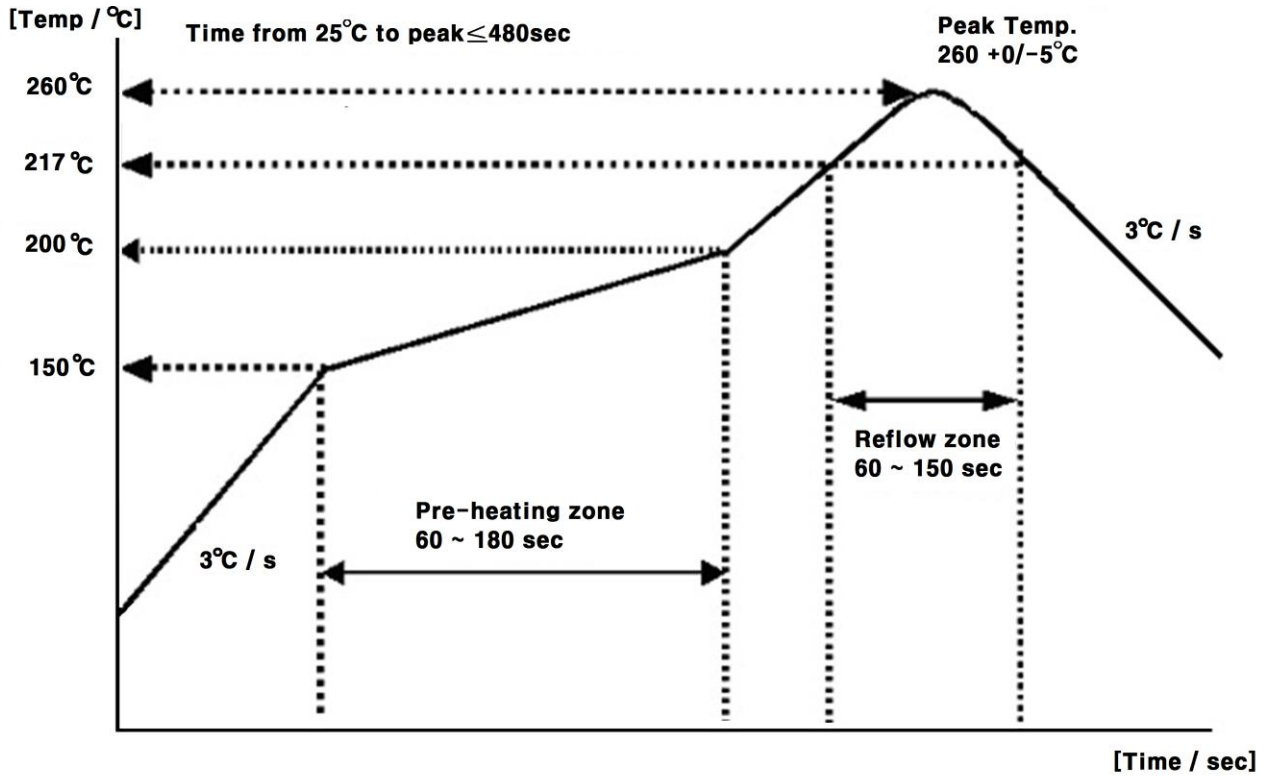

9. RECOMMENDED PCB DIMENSIONS

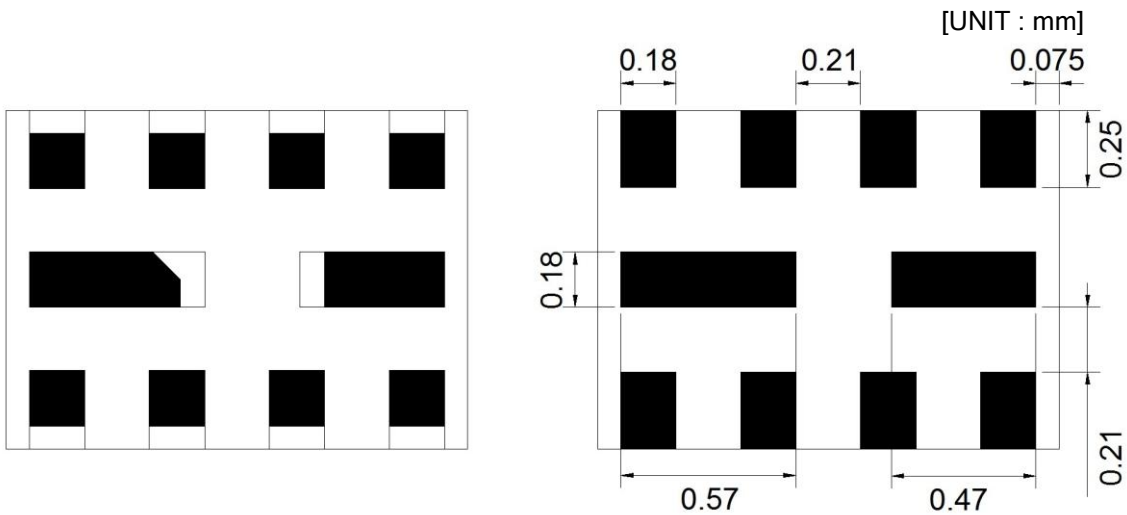

< SAW, X-ray Top View >

< PCB, X-ray Top View >

10. CAUTION

Moisture Sensitivity Device Caution (MSL LEVEL=2a)

1. Calculated shelf life in sealed bag : 12 month at < 40°C and < 90% relative Humidity(RH)
 2. Peak package body temperature : **260°C**
 3. After bag is opened, devices that will be subjected to reflow solder or other high temperature process must be
 - (a) Mounted within : 672 hours of factory conditions ≤30°C/60% RH, or
 - (b) Stored per J-STD-033
 4. Device require bake, before mounting, if :
 - (a) Humidity Indicator Card reads > 60% when read at 23±5°C
 - (b) 3(a) or 3(b) are not met
 5. If baking is required, refer to IPC/JEDEC J-STD-033 for bake procedure
- Note : Level and body temperature defined by IPC/JEDEC J-STD-020

Aluminum Pack (310mmX370mm)



HIC(Humidity Indication Card)

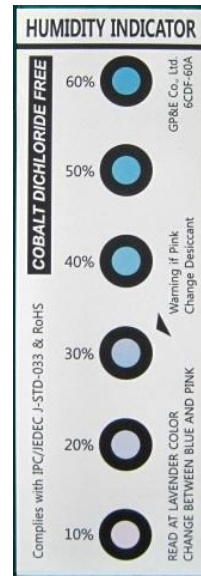

10 to 60% RH

11. PACKING

11-1. DIMENSIONS

- Carrier Tape

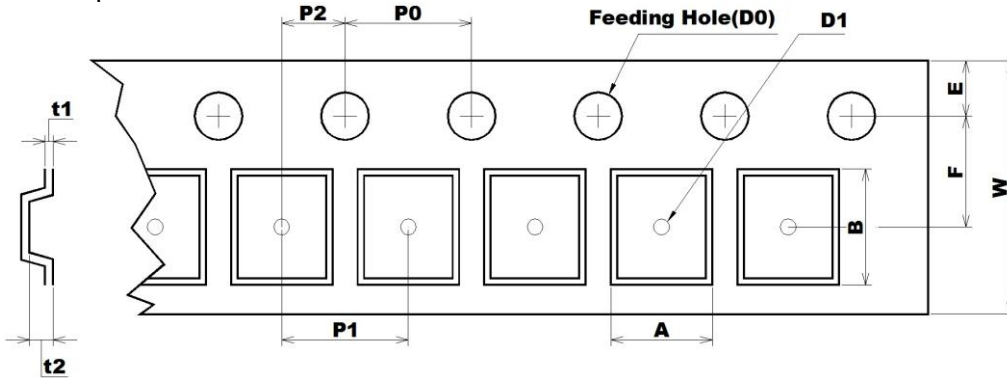

[Unit: mm]

A	B	D0	D1	E	F	P0	P1	P2	t1	t2	W
1.35	1.75	Ø1.50	Ø0.50	1.75	3.50	4.00	4.00	2.00	0.25	0.70	8.00
+0.05	+0.05	+0.10	+0.05	+0.10	+0.05	+0.10	+0.10	+0.05	+0.02	+0.07	+0.30
-0.05	-0.05	-0.00	-0.05	-0.10	-0.05	-0.10	-0.10	-0.05	-0.02	-0.07	-0.10

- Reel

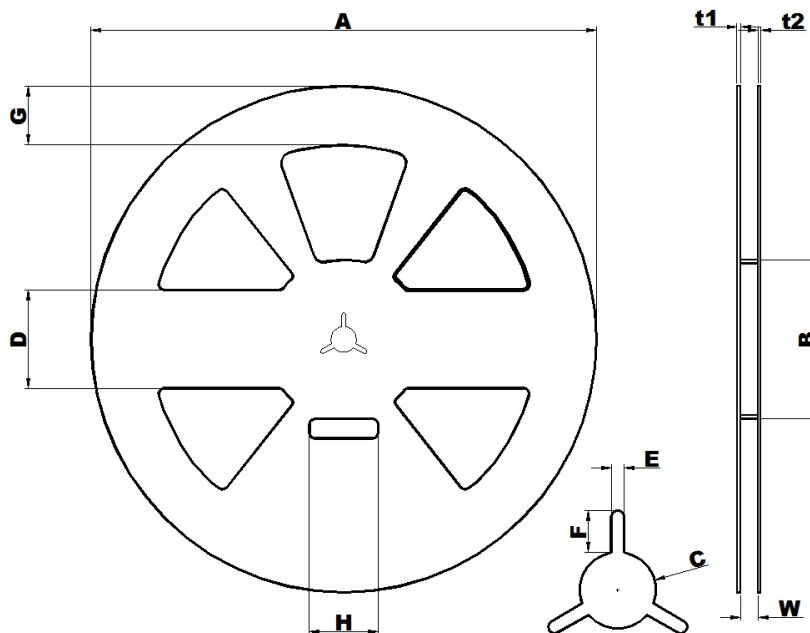

[Unit: mm]

A	B	C	D	E	F	G	H	t1	t2	W
Ø 258.0	Ø 81.0	Ø 13.0	50.0	2.2	7.0	30.0	35.0	1.8	1.5	9.0
+1.0	+1.0	+0.5	+0.8	+0.3	+0.5	+0.8	+1.0	+0.5	+0.5	+1.0
-0.5	-1.0	-0.5	-0.8	-0.3	-0.5	-0.8	-1.0	-0.5	-0.5	-0.5

- The product shall be packed properly not to damaged during transportation and storage.

11-2. REELING QUANTITY

10 inch reel : 8,000 pcs/reel

11-3. TAPING STRUCTURE

11-3-1. The tape shall be wound around the reel in direction shown below.

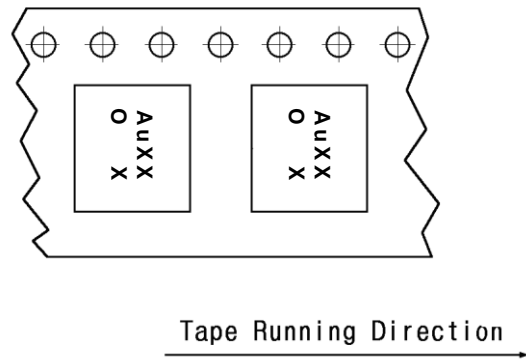
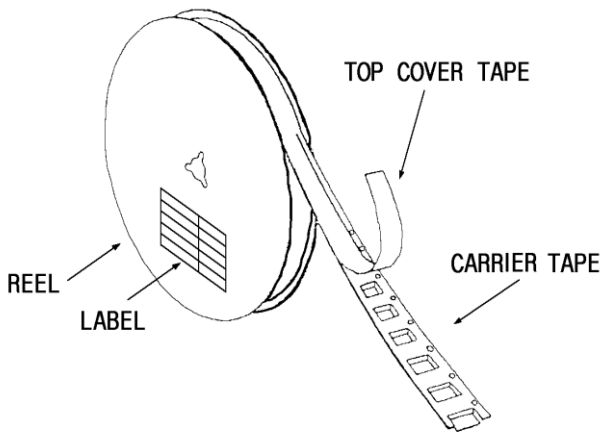

11-3-2. BAR CODE LABEL



- | | | |
|---|---|--------------------|
| ① |  | MODEL NAME BARCODE |
| ② | SFH836AQ101 | Model Name |
| ③ | RLYC12563 | Reel number |
| ④ | 8,000 / qAFYU | Quantity / Marking |

1-3-3. Leader part and vacant position specifications.

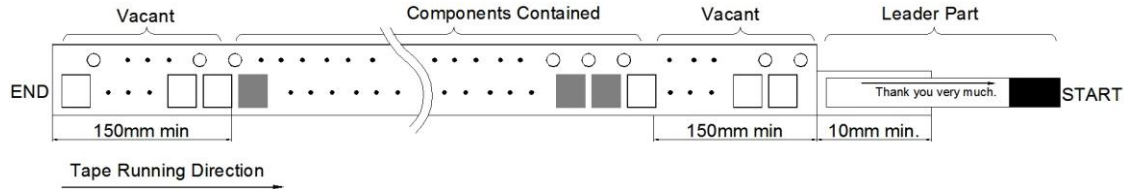

11-4. INNER BOX(Reel Packing) STRUCTURE

Material: Polycarbonate

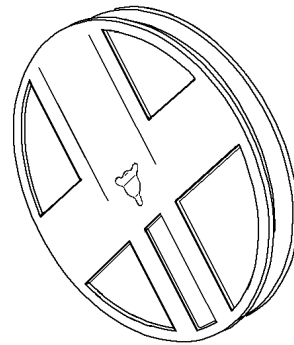

Material: Polyethylene + Aluminium

Size: 310×370mm²

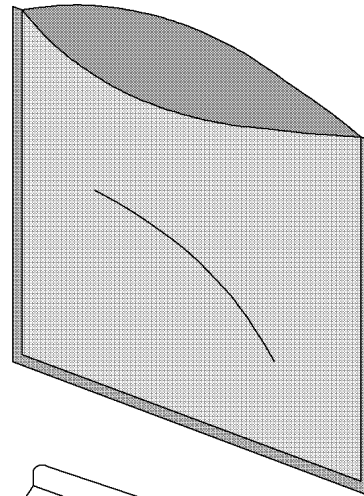

Material: Paper

Size: (D)260×(W)37×(H)265mm³

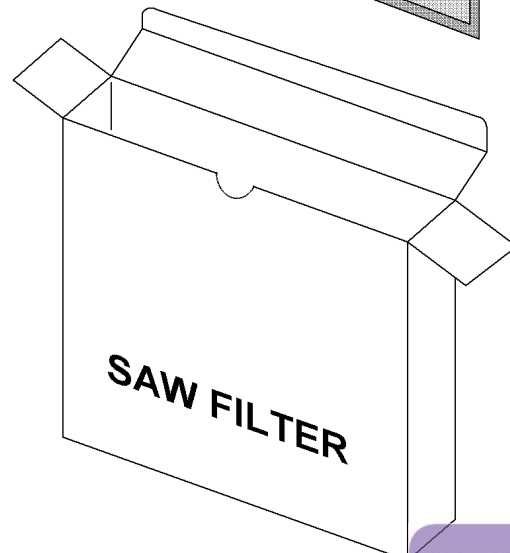

购买原装正品请认准-德方电子
 免费服务热线: 400-655-8700
 深圳总部电话: 0755-28187877
 网址: www.denovocn.com

11-5. OUTER BOX STRUCTURE

Material: Paper

TYPE	SIZE(mm)			Inner Box #
	a	b	c	
A	270	240	275	6 boxes

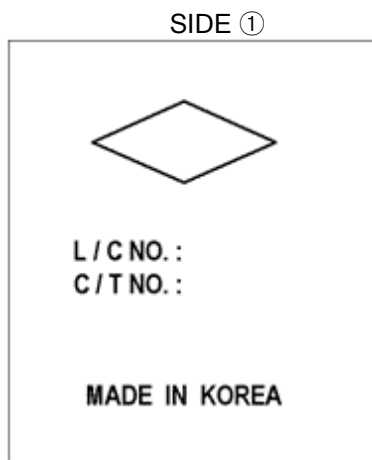
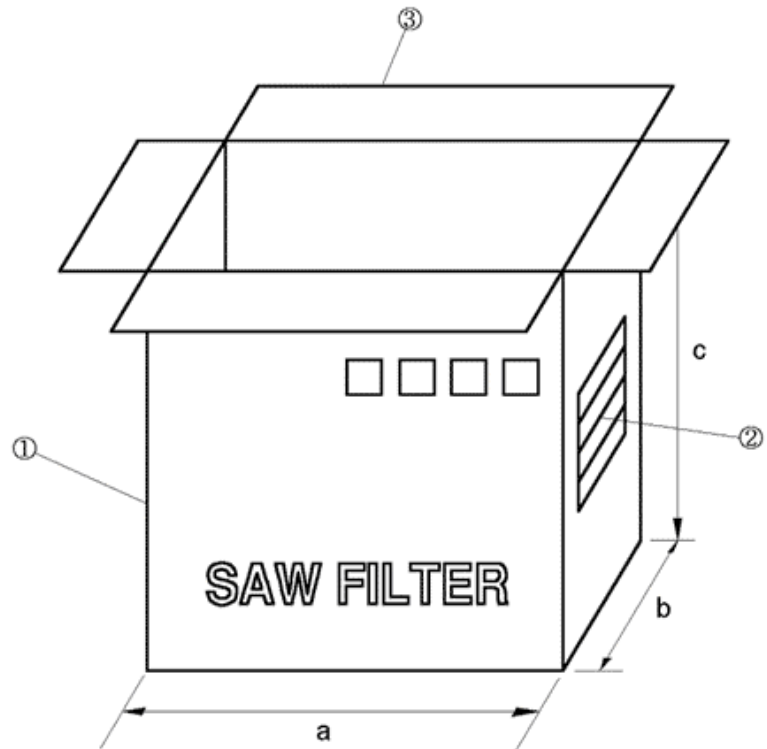

SIDE ②

MODEL	
Q'TY	EA
USER	
DATE	. . .

- SIDE is the same as front side.

12. TAPE SPECIFICATIONS

12-1. Tensile Strength of Carrier Tape: 4.4N/mm width

12-2. Top Cover Tape Adhesion (See the below figure)

- pull of angle: 0~15 degree
- speed: 300mm/min.
- force: 20~70g

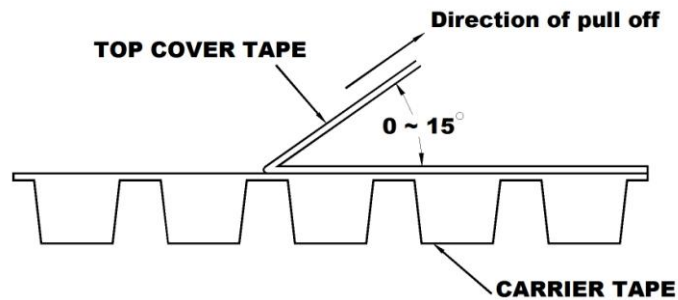



Test Report No. F690101/LF-CTSAYAA13-31939

Issued Date: 2013. 07. 08 Page 4 of 6

Testing Flow Chart for RoHS: Cd/Pb/Hg/Cr⁶⁺ /PBBs&PBDEs Testing

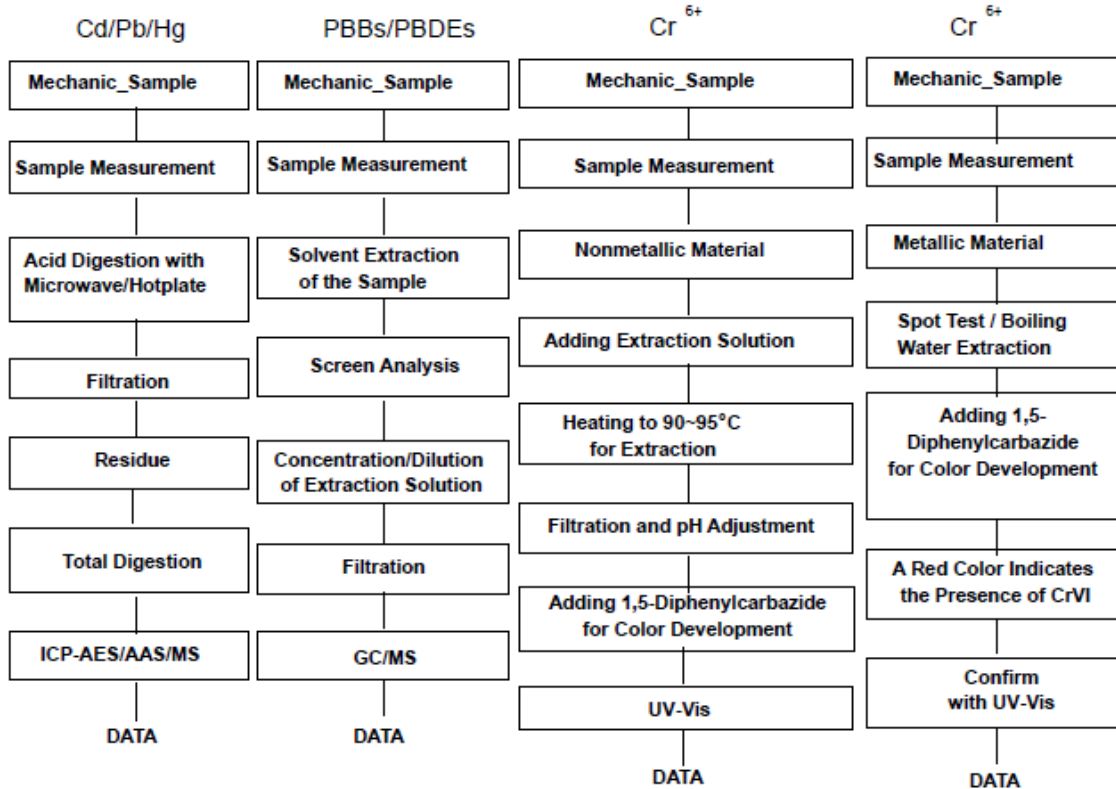

The samples were dissolved totally by pre-conditioning method according to above flow chart for Cd,Pb,Hg.
Section Chief : Gilsae Yi

NOTE:

- (1) N.D. = Not detected (<MDL)
- (2) mg/kg = ppm
- (3) MDL = Method Detection Limit
- (4) - = No regulation
- (5) Negative = Undetectable / Positive = Detectable
- (6) ** = Qualitative analysis (No Unit)
- (7) * = Boiling-water-extraction:
Negative = Absence of CrVI coating
Positive = Presence of CrVI coating: the detected concentration in boiling-water-extraction solution is equal or greater than 0.02 mg/kg with 50 cm² sample surface area.

The document is issued by the Company subject to the General Conditions of Service (attached herewith) available on request or accessible at http://www.sgs.com/conditions_of_service and http://www.sgs.com/conditions_of_service_ko for electronic format documents subject to Terms and Conditions for Electronic Documents at http://www.sgs.com/electronic_documents. Attention is drawn to the limitation of liability, indemnification and jurisdiction clause defined therein. Any value of the document is subject to the information contained therein which is the Company's finding at the time of its intervention only and within the limits of Client's instructions. If any of the Company's sole responsibility is to the Client and the document does not constitute parties to a transaction from accepting their rights and obligations under the transaction documents. The document cannot be reproduced without the written prior approval of the Company. Any unauthorized alteration, forgery or falsification of the content or appearance of this document is unlawful and offenders may be prosecuted to the fullest extent of the law. (Some references within the report shown in this test report refer only to the secondary tested and test equipment are mentioned for 30 days only.)

SGS Korea Co., Ltd.

322, The O valley, 555-9, Hogeys-dong, Dongan-gu, Anyang-si, Gyeonggi-do, Korea 431-080
T +82 (0)31 4808 000 F +82 (0)31 4808 050 <http://www.sgsksh.co.kr> www.kr.sgs.com/sgsksh

F052 Version5

Member of the SGS Group (Société Générale de Surveillance)

购买原装正品请认准-德方电子
免费服务热线: 400-655-8700
深圳总部电话: 0755-28187877
网址: www.denovocn.com
July 30, 2013



Test Report No. F690101/LF-CTSAYAA13-31939

Issued Date: 2013. 07. 08 Page 5 of 6

Flow Chart for Inorganic Elements Testing

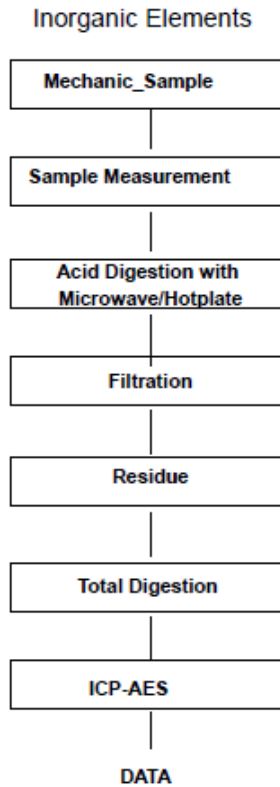

NOTE:

- (1) N.D. = Not detected.(<MDL)
- (2) mg/kg = ppm
- (3) MDL = Method Detection Limit
- (4) - = No regulation
- (5) Negative = Undetectable / Positive = Detectable
- (6) ** = Qualitative analysis (No Unit)
- (7) * = Boiling-water-extraction:
Negative = Absence of CrVI coating
Positive = Presence of CrVI coating; the detected concentration in boiling-water-extraction solution is equal or greater than 0.02 mg/kg with 50 cm² sample surface area.

* Document is issued by the Company subject to its General Conditions of Service printed hereon, available on request or accessible at <http://www.sgs.com/ChinaandConfidence> and, for electronic format documents, subject to Terms and Conditions for Electronic Documents at <http://www.sgs.com/ChinaandConfidence>. Attention is drawn to the limitation of liability, indemnification and jurisdiction clause printed hereon. Any holder of the document is advised that information contained herein reflects the Company's findings at the time of its intervention only and within the limits of Client's instructions. If the Company's work responsibility is to be Client and the document does not constitute parties to a transaction from executing of their rights and obligations under the transaction documents. The document cannot be reproduced or used without prior written approval of the Company. Any reproduction, alteration, forgery or falsification of the content or appearance of the document is unlawful and offenders may be prosecuted to the fullest extent of the law. See also terms stated for results shown in this test report when only the sample(s) tested and each sample(s) are retained for 30 days only.

购买原装正品请认准-德方电子
免费服务热线: 400-655-8700
深圳总部电话: 0755-28187877
网址: www.denovocn.com
July 30, 2013



Test Report No. F690101/LF-CTSAYAA13-31939

Issued Date: 2013. 07. 08 Page 6 of 6

Flow Chart for Halogen Test

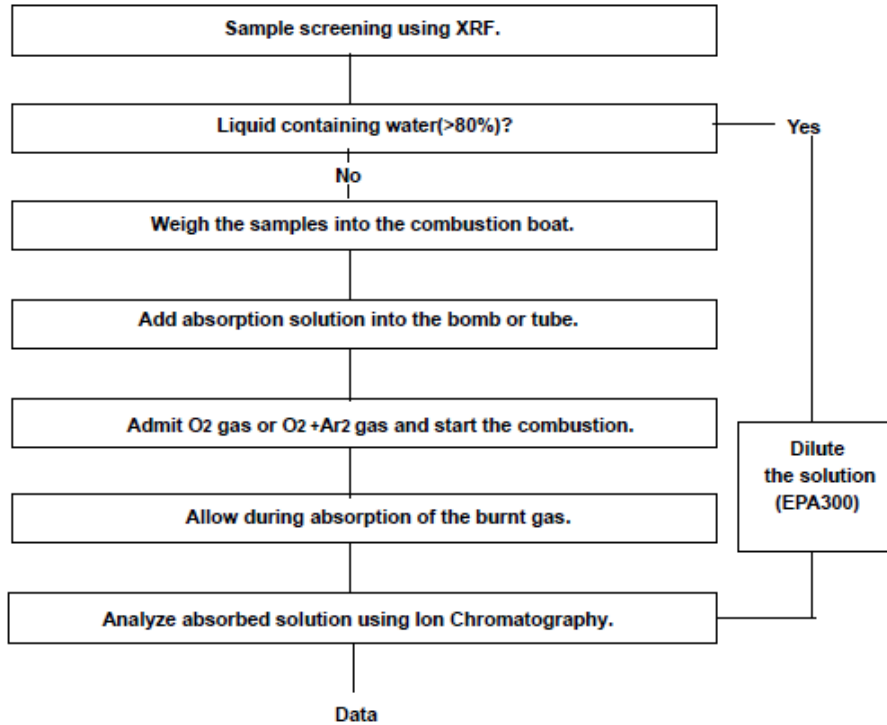

*** End ***

NOTE:

- (1) N.D. = Not detected.(<MDL)
- (2) mg/kg = ppm
- (3) MDL = Method Detection Limit
- (4) - = No regulation
- (5) Negative = Undetectable / Positive = Detectable
- (6) ** = Qualitative analysis (No Unit)
- (7) * = Boiling-water-extraction:
 Negative = Absence of CrVI coating
 Positive = Presence of CrVI coating; the detected concentration in boiling-water-extraction solution is equal or greater than 0.02 mg/kg with 50 cm2 sample surface area.

This document is issued by the Company subject to its General Conditions of Service (printed or online), available on request or accessible at <http://www.sgs.com/ChinaandCIS/Service> and, for electronic format documents, subject to Terms and Conditions for Electronic Documents at <http://www.sgs.com/ChinaandCIS/Service>. Attention is drawn to the limitation of liability, indemnification and jurisdiction issues defined therein. Any holder of this document is advised that information contained herein reflects the Company's findings at the time of its intervention only and within the limits of Client's instructions. It is the Client's sole responsibility as to the Client and this document does not constitute advice in a transaction from entering all their rights and obligations under the transaction documents. This document cannot be reproduced except in full, without prior written approval of the Company. Any unauthorized alteration, forgery or falsification of the content or appearance of this document is unlawful and offenders may be prosecuted to the fullest extent of the law. (See also terms agreed to the results shown in this test report only (see the samples) tested and each sample(s) are retained for 30 days only.

购买原装正品请认准-德方电子
 免费服务热线: 400-655-8700
 深圳总部电话: 0755-28187877
 网址: www.denovocn.com
 July 30, 2013