



SPECIFICATION

Surface Acoustic Wave Filter

USER

USER PART No.

WISOL PART No. **SFHG89GA002**

DOC. No. SMS-51-L-SFT FX-14

DATE March 19, 2013

REVISION 000

WISOL					
ISSUED BY	Hong, Byung-Chul 	APPROVED BY (R&D)	Hong, Seong-Su 	APPROVED BY (QC)	Jeon. Hyeon Cheol
User					
ISSUED BY		CHECKED BY		APPROVED BY	

WISOL CO., LTD.
 373-7, GAJANG-DONG, OSAN-SI,
 GYUNGGI-DO, KOREA, 447-210
<http://www.wisol.co.kr>

购买原装正品请认准-德方电子
 免费服务热线: 400-655-8700
 深圳总部电话: 0755-28187877
 网址: www.denovocn.com

COMPASS Rx 1561.10MHz
GPS Rx 1575.42MHz
GLONASS Rx 1601.72MHz
1.1×0.9×0.5mm³ 5pin lay-out
Version : 000
▶ A TABLE OF CONTENTS

1. REVISION HISTORY	3
2. DEFINITION	4
3. PRECAUTIONS	4
4. OUTLINE DRAWING & DIMENSIONS	5
5. MARKING	6
6. PERFORMANCE	7
6-1. MAXIMUM RATINGS	7
6-2. ELECTRICAL CHARACTERISTICS	8
7. RELIABILITY	10
7-1. ENGINEERING SAMPLE FLOW CHART	10
7-2. TEST ITEM & CONDITION	11
9. RECOMMENDED PCB DIMENSIONS	12
10. CAUTION	13
11. PACKING	14
11-1. DIMENSIONS	14
11-2. REELING QUANTITY	15
11-3. TAPING STRUCTURE	15
11-4. INNER BOX(Reel Packing) STRUCTURE	16
11-5. OUTER BOX STRUCTURE	17
12. TAPE SPECIFICATIONS	18
13. RoHS DATA	19

购买原装正品请认准-德方电子
 免费服务热线: 400-655-8700
 深圳总部电话: 0755-28187877
 网址: www.denovocn.com

COMPASS Rx 1561.10MHz

GPS Rx 1575.42MHz

GLONASS Rx 1601.72MHz

1.1×0.9×0.5mm³ 5pin lay-out

Version : 000

1. REVISION HISTORY

000 March 19, 2013 All page Make specification

购买原装正品请认准-德方电子
免费服务热线: 400-655-8700
深圳总部电话: 0755-28187877
网址: www.denovocn.com

COMPASS Rx 1561.10MHz
GPS Rx 1575.42MHz
1.1×0.9×0.5mm³ 5pin lay-out
Version : 000
GLONASS Rx 1601.72MHz

2. DEFINITION

2-1. PART No.

S F H G 8 9 G A 0 0 2
 (1) (2) (3) (4) (5) (6)

No.	EXPLANATION	
(1)	SAW Filter	
(2)	Design Type	
(3)	Center Frequency:	1561.10MHz(1559.10 ~ 1563.10) 1575.42MHz(1574.42 ~ 1576.42) 1601.72MHz(1597.55 ~ 1605.89)
(4)	Input:50ohm,Output:50ohm	
(5)	Package size: 1.1×0.9mm	
(6)	Design Revision (02: Molding type)	

2-2. APPLICATION : Band-Pass Filter for COMPSS & GPS & GNSS Rx etc

3. PRECAUTIONS

3-1. This device should not be used in any type of fluid such as water, oil, organic solvent, etc.

3-2. This is a hermetic device.

MSL(Moisture Sensitive Level) is the '2a' level.

3-3. Ultrasonic cleaning shall be avoided.

3-4. Isopropyl Alcohol and Ethyl Alcohol can be used for cleaning. Contact us before using other cleaning solvents than above

3-5. This is an electrostatic sensitive device.

Please avoid static voltage during operation and storage.

3-6. Sudden change of temperature shall be avoided, deterioration of the characteristics can occur.

3-7. If any malfunction due to designing or manufacturing which is out of specification occurs within one year after the products have been delivered, the maker should exchange the defective products.

购买原装正品请认准-德方电子
 免费服务热线: 400-655-8700
 深圳总部电话: 0755-28187877
 网址: www.denovocn.com

4. OUTLINE DRAWING & DIMENSIONS

[Unit: mm]

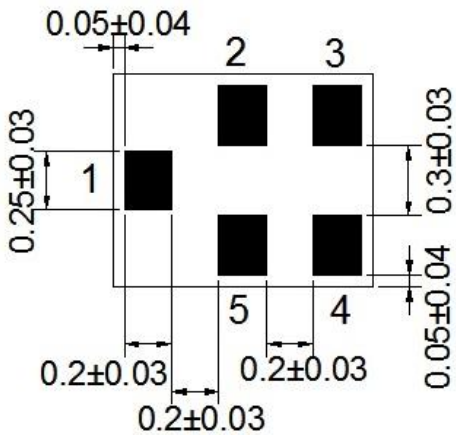
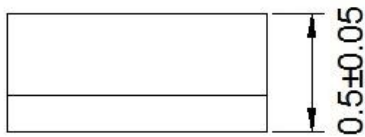
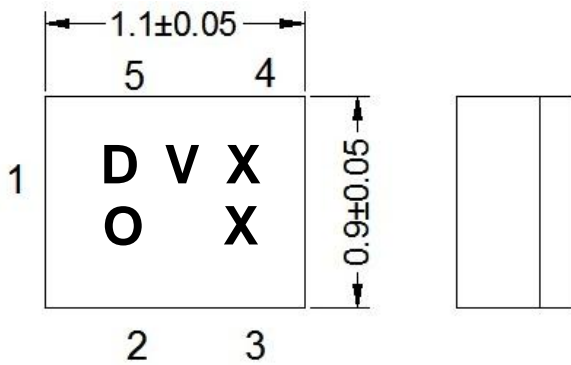

No.	Function
2, 3, 5	Ground
1	Unbalanced Input
4	Unbalanced Output

购买原装正品请认准-德方电子
 免费服务热线: 400-655-8700
 深圳总部电话: 0755-28187877
 网址: www.denovocn.com

COMPASS Rx 1561.10MHz
GPS Rx 1575.42MHz
1.1×0.9×0.5mm³ 5pin lay-out
Version : 000
GLONASS Rx 1601.72MHz

5. MARKING



5-1. DVX X

- The 1st, 2nd character 'DV' indicates the model name of SAW Filter “SFHG89GA002” .
- The 3rd character 'X' indicates the year and the month of manufacture.

Year	Month											
	1	2	3	4	5	6	7	8	9	10	11	12
2013	P	Q	R	S	T	U	V	W	X	Y	Z	a
2014	1	2	3	4	5	6	7	8	9	A	B	C
2015	D	E	F	G	H	I	J	K	L	M	N	O
2016	P	Q	R	S	T	U	V	W	X	Y	Z	a

※ This rotates by the 3 years.

- The 4th character 'X' indicates day of manufacture.

5-2. ○

- This symbol indicates input pin 1.
- This indicates the producing center
○: China

5-3. Marking: Laser Marking

购买原装正品请认准-德方电子
 免费服务热线: 400-655-8700
 深圳总部电话: 0755-28187877
 网址: www.denovocn.com

COMPASS Rx 1561.10MHz
GPS Rx 1575.42MHz
GLONASS Rx 1601.72MHz
1.1×0.9×0.5mm³ 5pin lay-out
Version : 000

6. PERFORMANCE

6-1. MAXIMUM RATINGS

CHARACTERISTICS	RATINGS	UNITS
DC Permissive Voltage	5	V
Maximum Input Power	15	dBm
Operating Temperature Range	- 30 ~ +85	℃
Storage Temperature Range	- 40 ~ +85	℃

购买原装正品请认准-德方电子
 免费服务热线: 400-655-8700
 深圳总部电话: 0755-28187877
 网址: www.denovocn.com

COMPASS Rx 1561.10MHz
GPS Rx 1575.42MHz
1.1×0.9×0.5mm³ 5pin lay-out
Version : 000
GLONASS Rx 1601.72MHz
6-2. ELECTRICAL CHARACTERISTICS
6-2-1. TABLE

Ta = -30 ~ +85°C

Item	FREQUENCY RANGE [MHz]	UNIT	SPECIFICATIONS		
			Min.	Typ. (25°C)	Max.
Insertion Loss	1559.10 ~ 1563.10	dB	-	1.3	1.6
Insertion Loss	1574.42 ~ 1576.42	dB	-	1.0	1.3
Insertion Loss	1597.55 ~ 1605.89	dB	-	1.4	1.7
VSWR(IN/OUT)	1559.10 ~ 1563.10	-	-	1.2	1.7
VSWR(IN/OUT)	1574.42 ~ 1576.42	-	-	1.2	1.6
VSWR(IN/OUT)	1597.55 ~ 1605.89	-	-	1.3	1.8
Absolute Attenuation	DC ~ 960	dB	37	40	
	1427 ~ 1463	dB	40	44	
	1710 ~ 1785	dB	35	38	
	1850 ~ 1910	dB	35	38	
	1920 ~ 1980	dB	35	38	
	2400 ~ 2483	dB	42	45	
	2500 ~ 2570	dB	42	45	
	2570 ~ 3000	dB	38	43	
	4900 ~ 6000	dB	23	27	
Terminating impedance		Input: Unbalanced 50 ohm Output: Unbalanced 50 ohm			

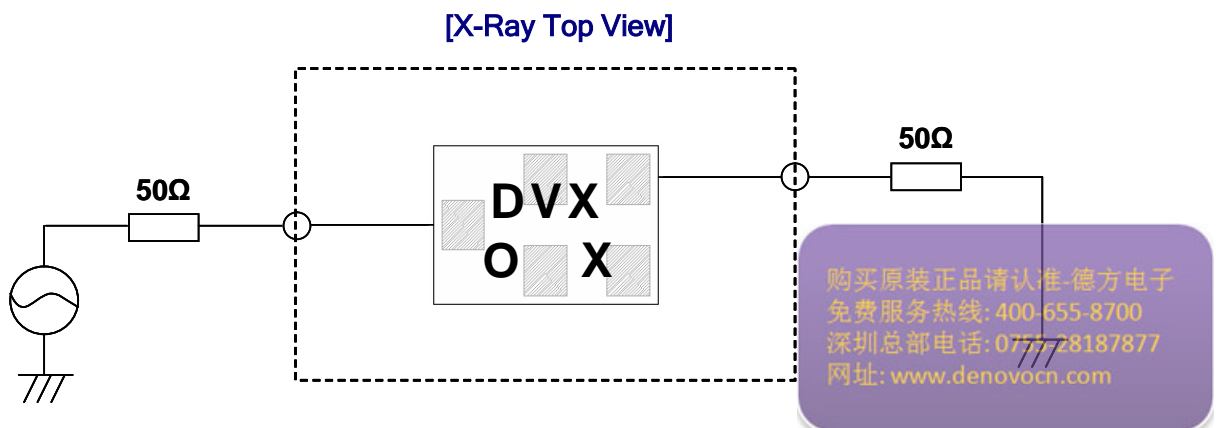
6-2-2. TEST FIXTURE

6-2-3. GRAPH

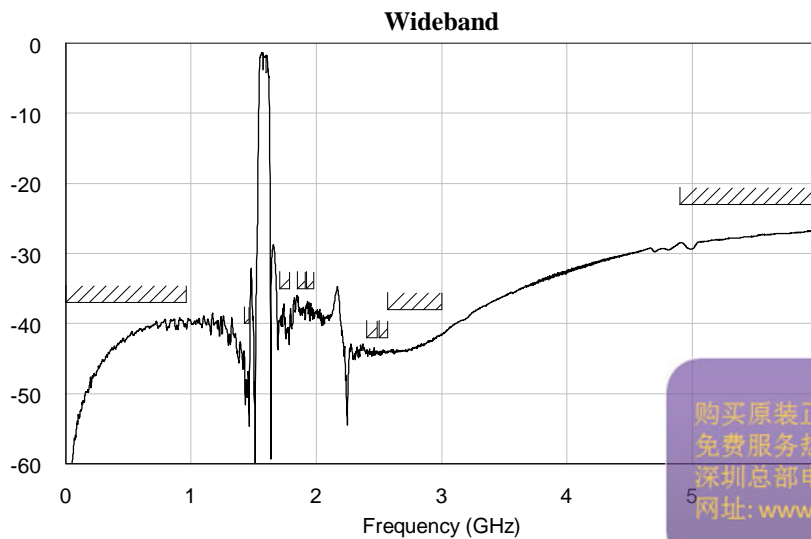
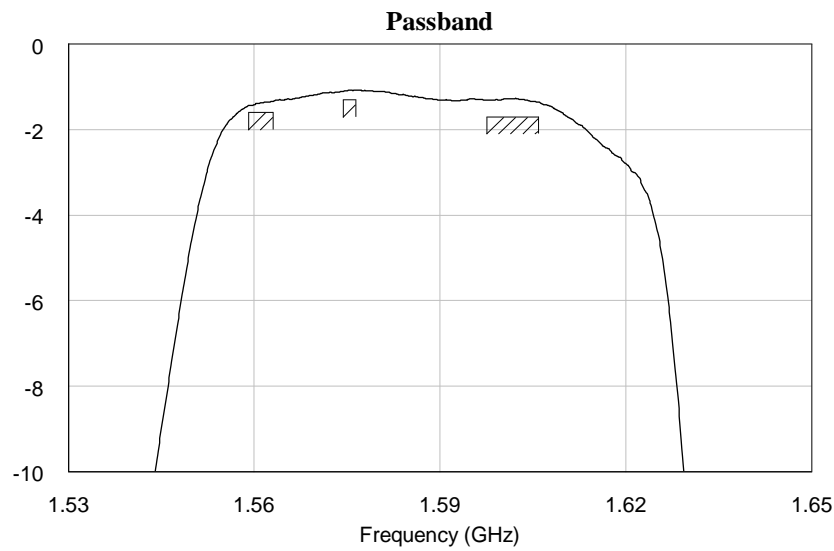
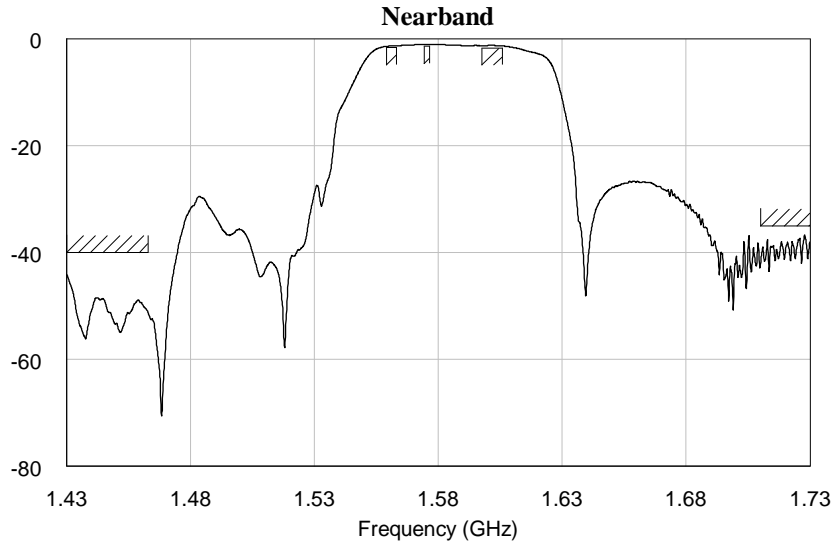

购买原装正品请认准-德方电子
 免费服务热线: 400-655-8700
 深圳总部电话: 0755-28187877
 网址: www.denovocn.com

7. RELIABILITY

7-1. ENGINEERING SAMPLE FLOW CHART

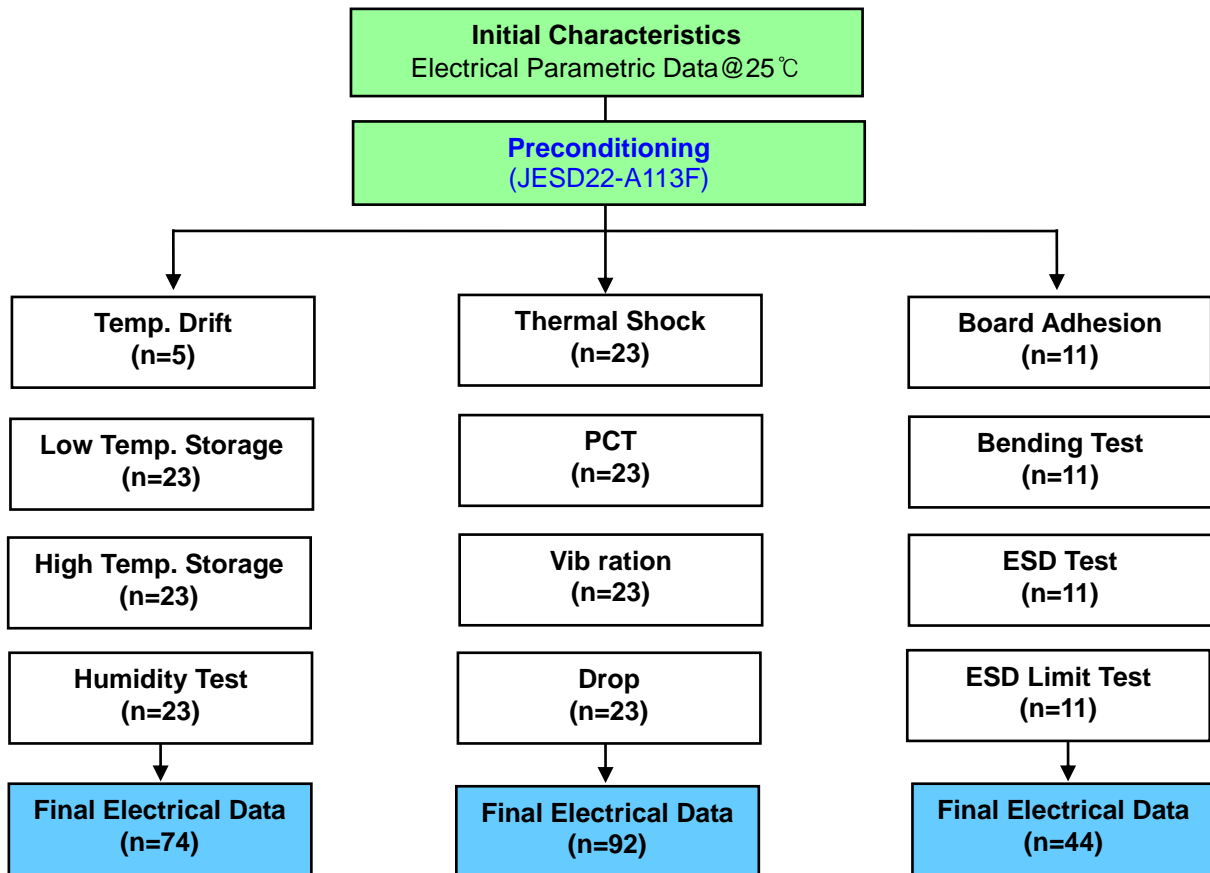

购买原装正品请认准-德方电子
 免费服务热线: 400-655-8700
 深圳总部电话: 0755-28187877
 网址: www.denovocn.com

COMPASS Rx 1561.10MHz
GPS Rx 1575.42MHz
1.1×0.9×0.5mm³ 5pin lay-out
Version : 000
GLONASS Rx 1601.72MHz
7-2. TEST ITEM & CONDITION

CATEGORY	TEST ITEM	TEST CONDITION	REMARK
	Preconditioning	+125℃ 24hr Baking → +60℃ 60%RH 120hr → Reflow Test(3times)	JESD22A113F



Environment Test	Temp. Drift	-30℃ → +25℃ → +85℃	description
	High Temp. Storage	+85℃ 240hr	JESD22-A103C
	Low Temp. Storage	-40℃ 240hr	JESD22-A119
	High Temp. High Humidity Storage	+85℃ 85%RH 240hr	JESD22-A106B
	Thermal Shock	-40℃/30min ⇔ +85℃/30min , 100cycle	JESD22-A106A
	High Temp. Operating	+121℃ 100%RH 96hr	JESD22-A102C
Mechanical Test	Vibration Test (Random)	20 Hz~2000 Hz,0.053G ² /Hz or 8gs RMS,15min/plane	IEC 68-2-36 Fdb
	Drop Test	152 cm 12times Steel floor JIG(110g~150g)	IEC 1178-1.4.8.9
	Board Adhesion	0.5 mm/sec 1point push	IEC 68-2-21 Ue3
	Bending Test	0.5 mm/sec 3times -PCB : FR4 , PCB SIZE : 100*40 mm	IEC 68-2-21 Ue3
Physical Test	Solder Heat Resistance	±250V,C=100pF,R=1.5 kΩ,1times	IEC 68-2-21 Ue3
	static marginal test	C=100pF,R=1.5 kΩ,1times(demand of customer)	JESD22-A114F

购买原装正品请认准-德方电子
 免费服务热线: 400-655-8700
 深圳总部电话: 0755-28187877
 网址: www.denovocn.com

8. REFLOW CONDITION

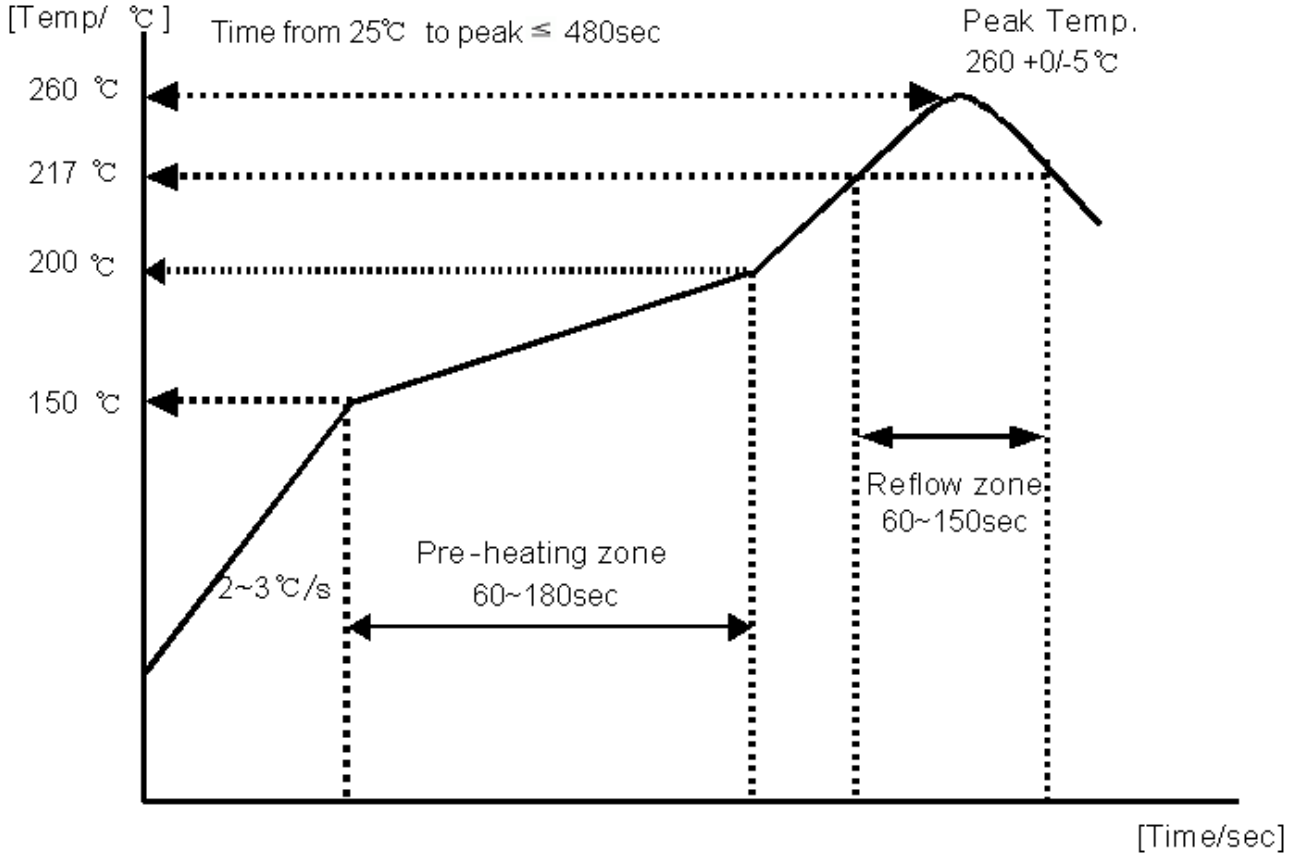

9. RECOMMENDED PCB DIMENSIONS

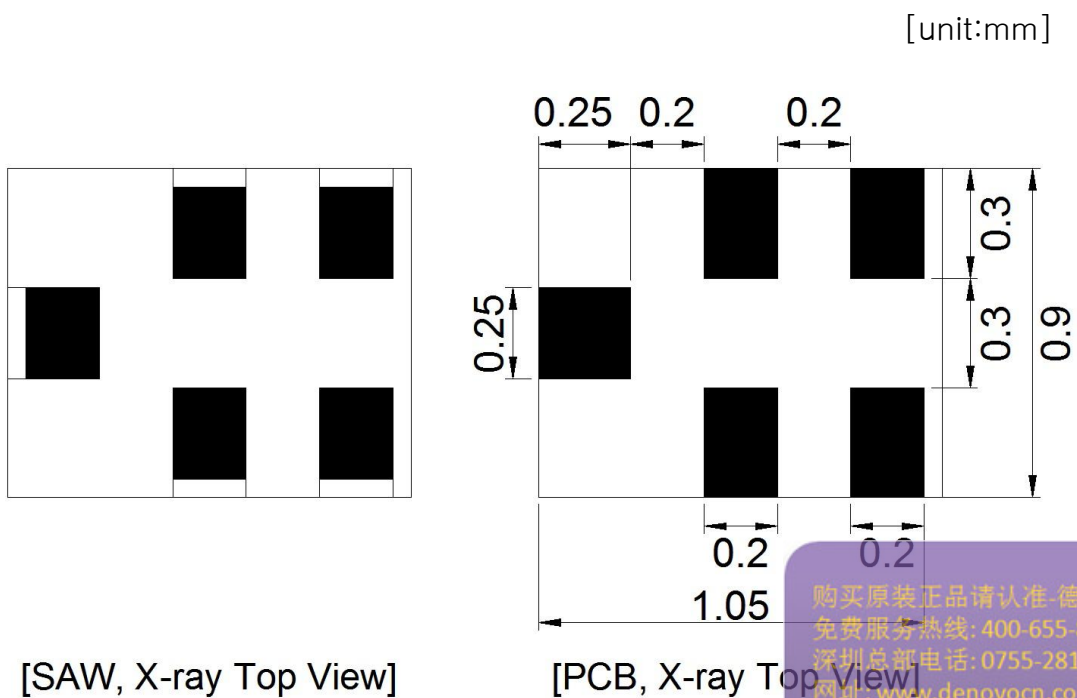

购买原装正品请认准-德方电子
 免费服务热线: 400-655-8700
 深圳总部电话: 0755-28187877
 网址: www.denovcn.com

COMPASS Rx 1561.10MHz
GPS Rx 1575.42MHz
1.1×0.9×0.5mm³ 5pin lay-out
Version : 000
GLONASS Rx 1601.72MHz

10. CAUTION

Moisture Sensitivity Device Caution (MSL LEVEL=2a)

1. Calculated shelf life in sealed bag : 12 month at <40°C and <90% relative Humidith(RH)
 2. Peak package body temperature : **260°C**
 3. After bag is opened, devices that will be subjected to reflow solder or other high temperature process must be
 - (a) Mounted within : 672 hours of factory conditions ≤30°C/60% RH, or
 - (b) Stored per J-STD-033
 4. Device require bake, before mounting, if :
 - (a) Humidity Indicator Card reads > 60% when read at 23±5°C
 - (b) 3(a) or 3(b) are not met
 5. If baking is required, refer to IPC/JEDEC J-STD-033 for bake proceddure
- Note : Level and body temperature defined by IPC/JEDEC J-STD-020

Aluminum Pack & Level (310mm X 370mm)



HIC(Humidity Indication Card)

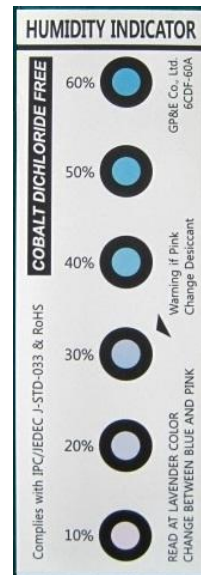

10 to 60% RH

购买原装正品请认准-德方电子
 免费服务热线: 400-655-8700
 深圳总部电话: 0755-28187877
 网址: www.denovocn.com

11. PACKING

11-1. DIMENSIONS

- Carrier Tape

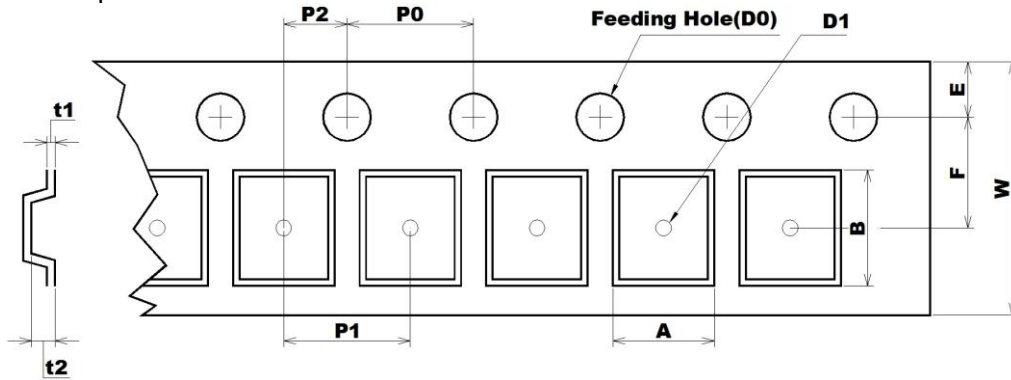

[Unit: mm]

A	B	D0	D1	E	F	P0	P1	P2	t1	t2	W
1.1	1.35	Ø1.50	Ø0.50	1.75	3.5	4	4	2	0.25	0.7	8
0.05	0.05	+0.10 -0.00	0.05	0.10	0.05	0.10	0.10	0.05	0.02	0.07	+0.30 -0.10

- Reel

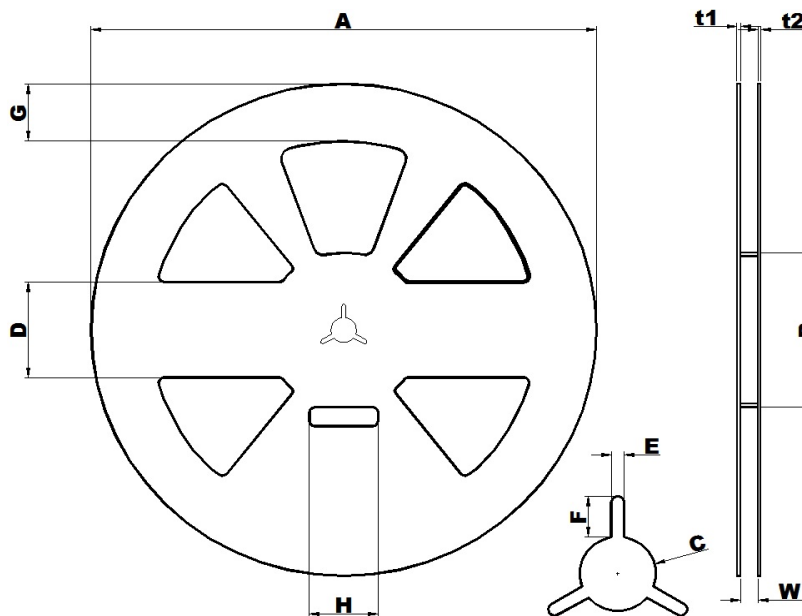

[Unit: mm]

A	B	C	D	E	F	G	H	t1	t2	W
Ø258.0	Ø81.0	Ø13.0	50.0	2.2	7.0	30.0	35.0	1.8	1.5	9.0
+1.0	1.0	0.5	0.8	0.3	0.5	0.8	1.0	购买原装正品请认准-德方电子 免费服务热线: 400-655-8700 深圳总仓电话: 055-28187877 网址: www.denovocn.com		
-0.5										

- The product shall be packed properly not to damaged during transportation and storage.

COMPASS Rx 1561.10MHz

GPS Rx 1575.42MHz

1.1×0.9×0.5mm³ 5pin lay-out

Version : 000

GLONASS Rx 1601.72MHz

11-2. REELING QUANTITY

10 inch reel: 10,000 pcs/reel

11-3. TAPING STRUCTURE

11-3-1. The tape shall be wound around the reel in direction shown below.

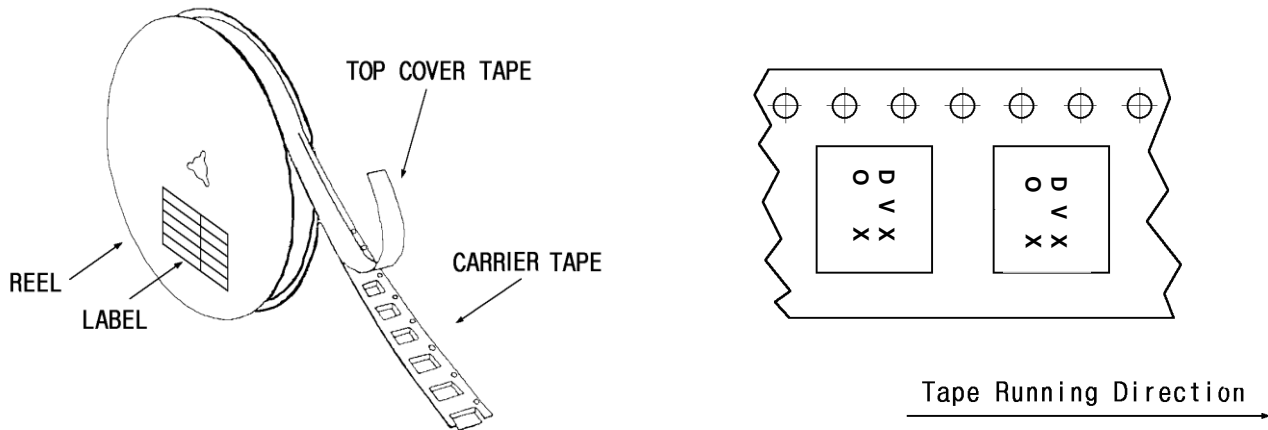

11-3-2. BAR CODE LABEL

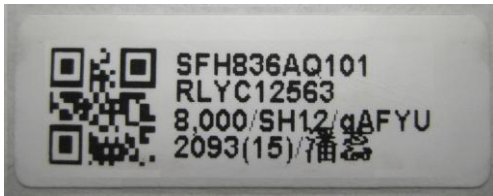

- (1)  MODEL NAME BARCODE
- (2) SFH836AQ101 Model Name
- (3) RLYC12563 Reel number
- (4) 8000 / qAFYU Quantity / Marking

购买原装正品请认准-德方电子
 免费服务热线: 400-655-8700
 深圳总部电话: 0755-28187877
 网址: www.denovocn.com

COMPASS Rx 1561.10MHz

GPS Rx 1575.42MHz

1.1×0.9×0.5mm³ 5pin lay-out

Version : 000

GLONASS Rx 1601.72MHz

11-3-3. Leader part and vacant position specifications.

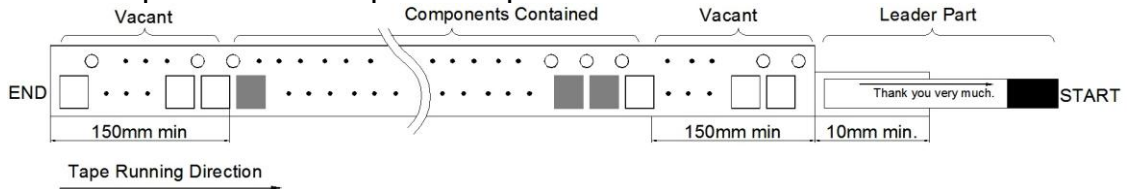

11-4. INNER BOX(Reel Packing) STRUCTURE

Material: Plastic Reel

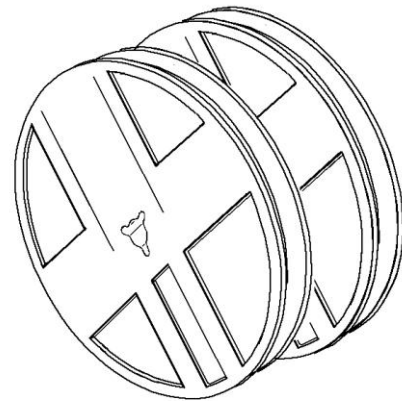

Material: Antistatic Vinyl Bag

Size: 310×340mm²

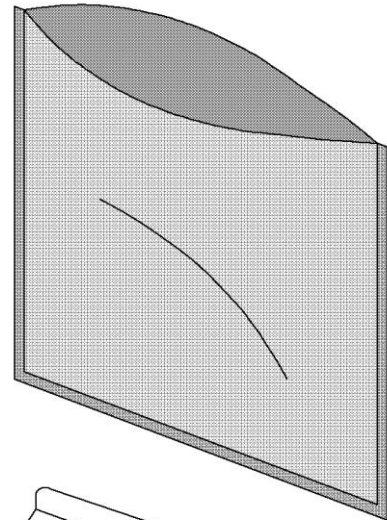

Material: Paper(SW1D(E))

Size: 260×37×265mm³

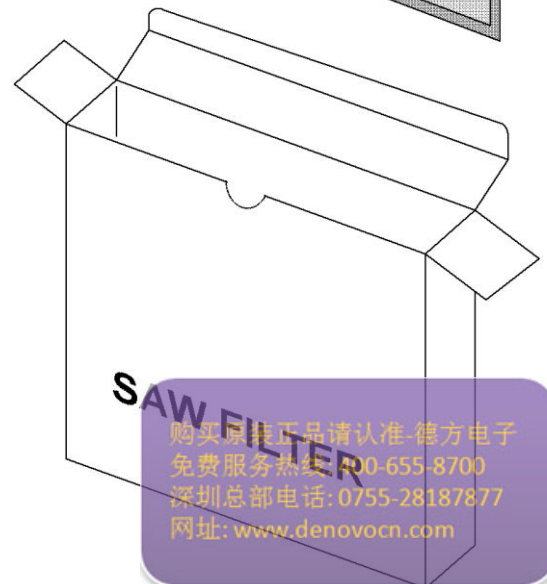

COMPASS Rx 1561.10MHz

GPS Rx 1575.42MHz

1.1×0.9×0.5mm³ 5pin lay-out

Version : 000

GLONASS Rx 1601.72MHz

11-5. OUTER BOX STRUCTURE

Material: Paper(SW3B(A))

TYPE	SIZE(mm)			Inner Box #
	a	b	c	
A	270	240	275	6 boxes

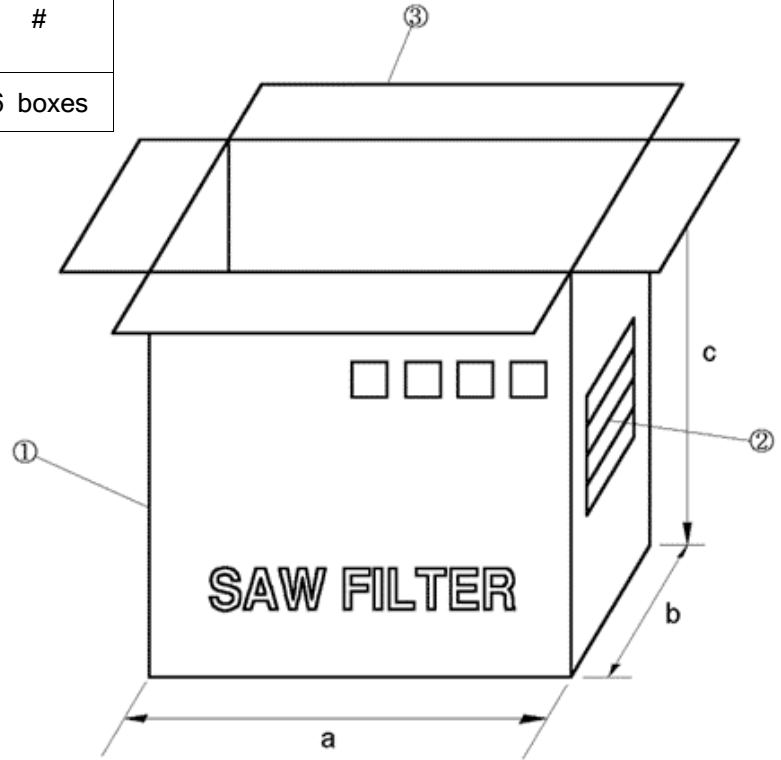

SIDE ①

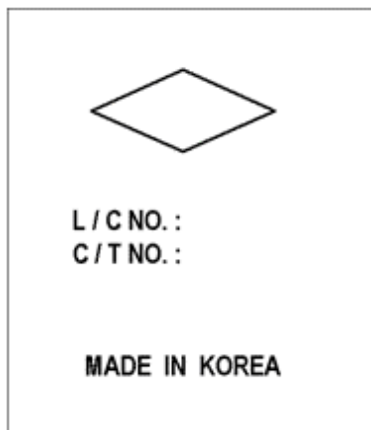

SIDE ②

MODEL	
Q'TY	EA
USER	
DATE	. .

- SIDE is the same as front side.

购买原装正品请认准-德方电子
 免费服务热线: 400-655-8700
 深圳总部电话: 0755-28187877
 网址: www.denovocn.com

COMPASS Rx 1561.10MHz
GPS Rx 1575.42MHz
1.1×0.9×0.5mm³ 5pin lay-out
Version : 000
GLONASS Rx 1601.72MHz

12. TAPE SPECIFICATIONS

12-1. Tensile Strength of Carrier Tape: 4.4N/mm width

12-2. Top Cover Tape Adhesion (See the below figure)

- pull of angle: 0~15 degree
- speed: 300mm/min.
- force: 20~70g

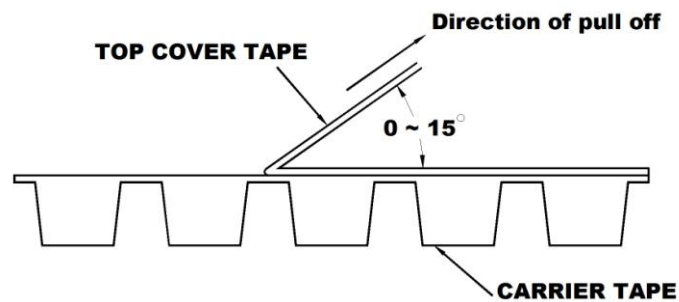

购买原装正品请认准-德方电子
 免费服务热线: 400-655-8700
 深圳总部电话: 0755-28187877
 网址: www.denovocn.com

COMPASS Rx 1561.10MHz
 GPS Rx 1575.42MHz 1.1×0.9×0.5mm³ 5pin lay-out Version : 000
 GLONASS Rx 1601.72MHz

13. RoHS DATA



Test Report No. F690101/LF-CTSAYAA11-28285

Issued Date: 2011. 09. 06 Page 1 of 2

To: WISOL CO., LTD.
 373-7
 Gajang-dong
 Osan-si
 Gyeonggi-do
 Korea

The following merchandise was submitted and identified by the client as :

SGS File No. : AYAA11-28285
 Product Name : SAW FILTER
 Item No./Part No. : N/A
 Received Date : 2011. 08. 31
 Test Period : 2011. 09. 01 to 2011. 09. 06
 Test Results : For further details, please refer to following page(s)
 Test Performed : SGS Korea tested the sample(s) selected by applicant with following results.
 Test Comments : By the applicant's specific request, the sampling and testing was performed only for the part indicated in the photo without disassembly.

SGS Korea Co. Ltd.



Jeff Jang / Chemical Lab Mgr

Timothy Jeon
 Jinhee Kim
 Cindy Park
 Jerry Jung / Testing Person

This document is issued by the Company subject to its General Conditions of Service printed hereinafter, available on request or accessible at www.sgs.com/terms_and_conditions.html, for electronic format documents, subject to Terms and Conditions for Electronic Documents (www.sgs.com/terms_e_documents.htm). Attention is drawn to the limitation of liability, indemnification and jurisdiction clause defined therein. Any holder of this document is advised that transmission constitutes an acknowledgment of the Company's liability at the time of its transmission only and after the limits of liability instructions. First: The customer is also responsible to the Client and this document does not constitute a contract. In a transaction that involving all their rights and obligations under the transaction documents. This document cannot be reproduced except in full, without prior written approval of the Company. Any unauthorized alteration, forgery or falsification of the content or appearance of this document is unlawful and offenders may be prosecuted to the fullest extent of the law. Unless otherwise stated the results shown in this test report refer only to the sample(s) tested and such sample(s) are retained for 180 days only.

FD52 Version4

SGS Korea Co., Ltd. 322, The O valley, 555-9, Hoge-dong, Dongan-gu, Anyang-si, Gyeonggi-do, Korea 431-080
 t +82 (0)31 4608 000 f +82 (0)31 4608 059 <http://www.sgslab.co.kr> www.kr.sgs.com/greenlab
 Member of the SGS Group (Société Générale de Surveillance)

购买原装正品请认准-德方电子
 免费服务热线: 400-655-8700
 深圳总部电话: 0755-28187877
 网址: www.denovocn.com

COMPASS Rx 1561.10MHz

GPS Rx 1575.42MHz

1.1×0.9×0.5mm³ 5pin lay-out

Version : 000

GLONASS Rx 1601.72MHz



Test Report No. F690101/LF-CTSAYAA11-28285

Issued Date: 2011. 09. 06 Page 2 of 2

Sample No. : AYAA11-28285.001

Sample Description : SAW FILTER

Item No./Part No. : N/A

Materials : N/A

Heavy Metals

Test Items	Unit	Test Method	MDL	Results
Antimony (Sb)	mg/kg	With reference to EPA 3052(1996), US EPA 8010B(1996), ICP	10	N.D.

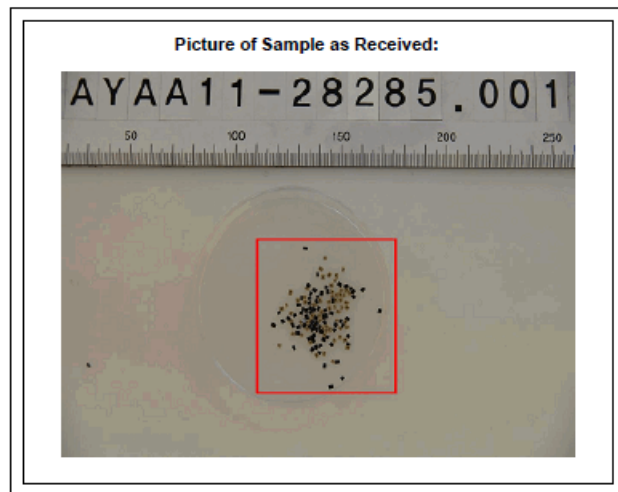

*** End ***

- NOTE: (1) N.D. = Not detected.(<MDL)
 (2) mg/kg = ppm
 (3) MDL = Method Detection Limit
 (4) - = No regulation
 (5) ** = Qualitative analysis (No Unit)
 (6) * = Boiling-water-extraction:
 Negative = Absence of CrVI coating
 Positive = Presence of CrVI coating; the detected concentration in boiling-water-extraction solution is equal or greater than 0.02 mg/kg with 50 cm² sample surface area.

This document is issued by the Company subject to its General Conditions of Service printed on the reverse side of this document, and, for electronic format documents, subject to Terms and Conditions for Electronic Documents (www.sgs.com/terms_e-document.htm). Attention is drawn to the limitation of liability, indemnification and jurisdiction clause defined therein. Any holder of this document is advised that it constitutes evidence between the Company and the Client only and within the limits of the Client's instructions. If any of the Company's use requirements is to be Client and this document does not accurately reflect the Client's instructions, the Client shall be responsible for the accuracy of the document. The document cannot be reproduced except in full, without prior written approval of the Company. Any use of this document, in whole or in part, for purposes other than those intended by the Company is prohibited. The document is issued for the Client's use only. Unless otherwise stated, the results shown in this test report refer only to the sample(s) tested and such sample(s) are retained for 180 days only.

F052 Version4

SGS Korea Co., Ltd.

322, The O valley, 555-9, Haegy-dong, Dongan-gu, Anyang-si, Gyeonggi-do, Korea 431-080
 t +82 (0)31 4608 000 f +82 (0)31 4608 959 <http://www.sgslab.co.kr> www.kr.sgs.com/greenlab

Member of the SGS Group (Société Générale de Surveillance)

购买原装正品请认准-德方电子
 免费服务热线: 400-655-8700
 深圳总部电话: 0755-28187877
 网址: www.denovocn.com