



SPECIFICATION

Surface Acoustic Wave Filter

USER

USER PART No.

SEMCO PART No. **SFH942PA002**

DOC. No. SMS-51-L-SFT FX-18

DATE July 24, 2013

REVISION 000

WISOL					
ISSUED BY	Kim, Kyung-Sik 	APPROVED BY (R&D)	Hong, Seong-Su 	APPROVED BY (QC)	Jeon. Hyeon Cheol
User					
ISSUED BY		CHECKED BY		APPROVED BY	

WISOL CO., LTD.
 373-7, GAJANG-DONG, OSAN-SI,
 GYUNGGI-DO, KOREA, 447-210
<http://www.wisol.co.kr>

购买原装正品请认准-德方电子
 免费服务热线: 400-655-8700
 深圳总部电话: 0755-28187877
 网址: www.denovocn.com

▶ A TABLE OF CONTENTS

1. REVISION HISTORY	3
2. DEFINITION	4
3. PRECAUTIONS	4
4. OUTLINE DRAWING & DIMENSIONS	5
5. MARKING	6
6. PERFORMANCE	7
6-1. MAXIMUM RATINGS	7
6-2. ELECTRICAL CHARACTERISTICS	8
7. RELIABILITY	10
7-1. ENGINEERING SAMPLE FLOW CHART	10
7-2. TEST ITEM & CONDITION	11
8. REFLOW CONDITION	12
9. RECOMMENDED PCB DIMENSIONS	12
11. PACKING	14
11-1. DIMENSIONS	14
11-2. REELING QUANTITY	15
11-3. TAPING STRUCTURE	15
11-4. INNER BOX(Reel Packing) STRUCTURE	16
11-5. OUTER BOX STRUCTURE	17
12. TAPE SPECIFICATIONS	18
13. RoHS DATA	19

购买原装正品请认准-德方电子
 免费服务热线: 400-655-8700
 深圳总部电话: 0755-28187877
 网址: www.denovocn.com

1. REVISION HISTORY

000	July 24, 2013	All Page	Make specification
-----	---------------	----------	--------------------

购买原装正品请认准-德方电子
免费服务热线: 400-655-8700
深圳总部电话: 0755-28187877
网址: www.denovocn.com

2. DEFINITION

2-1. PART No.

SFH942PA002

①	②	③	④	⑤	⑥
No.	EXPLANATION				
①	SAW Filter				
②	Design Type				
③	Center Frequency : 942.5MHz(925 ~ 960)				
④	Input:50ohm,Output:150ohm				
⑤	Package size: 1.1×0.9mm ²				
⑥	Design Revision (02 : Molding Type)				

2-2. APPLICATION : Band-Pass Filter for EGSM Rx etc (UMTS Band VIII)

3. PRECAUTIONS

3-1. This device should not be used in any type of fluid such as water, oil, organic solvent, etc.

3-2. This is a hermetic device.

MSL(Moisture Sensitive Level) is the '2a' level.

3-3. Ultrasonic cleaning shall be avoided.

3-4. Isopropyl Alcohol and Ethyl Alcohol can be used for cleaning. Contact us before using other cleaning solvents than above

3-5. This is an electrostatic sensitive device.

Please avoid static voltage during operation and storage.

3-6. Sudden change of temperature shall be avoided, deterioration of the characteristics can occur.

3-7. If any malfunction due to designing or manufacturing which is out of specification occurs within one year after the products have been delivered, the maker should exchange the defective products.

购买原装正品请认准-德方电子
 免费服务热线: 400-655-8700
 深圳总部电话: 0755-28187877
 网址: www.denovocn.com

4. OUTLINE DRAWING & DIMENSIONS

[Unit: mm]

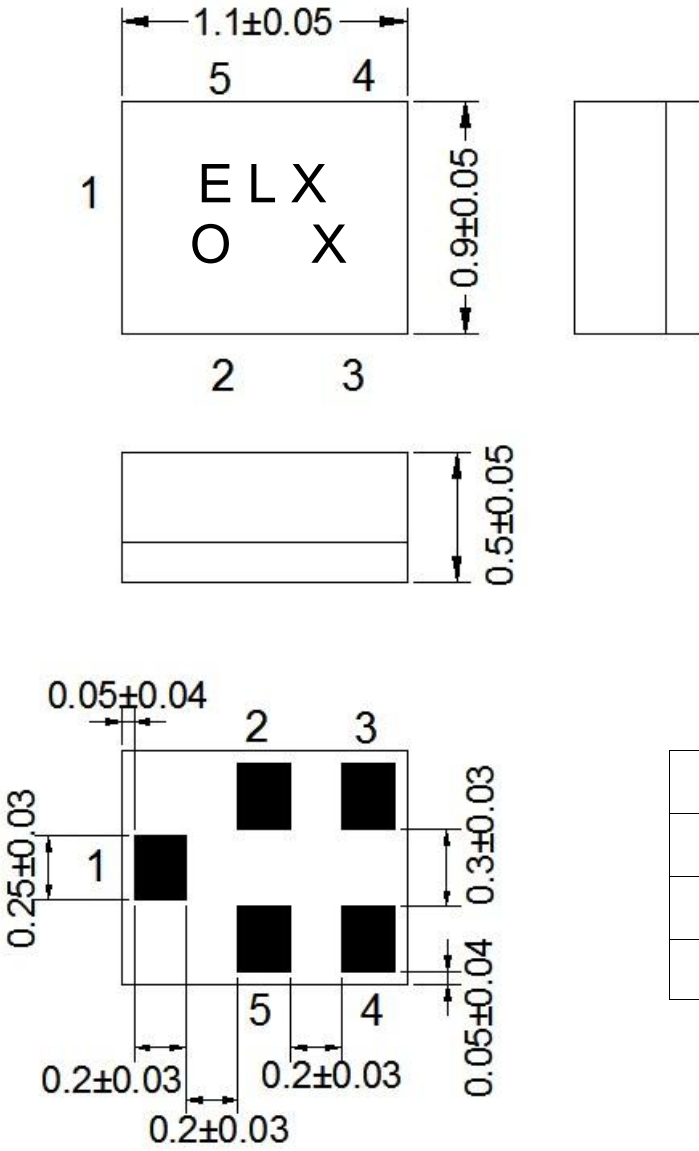

No.	Function
2, 5	Ground
1	Unbalanced Input
3,4	Balanced Output

购买原装正品请认准-德方电子
 免费服务热线: 400-655-8700
 深圳总部电话: 0755-28187877
 网址: www.denovocn.com

5. MARKING



5-1. E L X X

- The 1st 2nd character 'EL' indicates the model name of SAW Filter SFH942PA002.
- The 3rd character 'X' indicates the year and the month of manufacture.

Year	Month											
	1	2	3	4	5	6	7	8	9	10	11	12
2013	P	Q	R	S	T	U	V	W	X	Y	Z	a
2014	1	2	3	4	5	6	7	8	9	A	B	C
2015	D	E	F	G	H	I	J	K	L	M	N	O
2016	P	Q	R	S	T	U	V	W	X	Y	Z	a

※ This rotates by the 3 years.

- The 4th character 'X' indicates Lot No.

5-2. ○

- This symbol indicates input pin 1.
- This indicates the producing center
 - : China,

5-3. Marking : Laser Marking

购买原装正品请认准-德方电子
 免费服务热线: 400-655-8700
 深圳总部电话: 0755-28187877
 网址: www.denovocn.com

6. PERFORMANCE

6-1. MAXIMUM RATINGS

CHARACTERISTICS	RATINGS	UNITS
DC Permissive Voltage	5	V
Maximum Input Power	15	dBm
Operating Temperature Range	- 30 ~ +85	°C
Storage Temperature Range	- 40 ~ +85	°C

购买原装正品请认准-德方电子
 免费服务热线: 400-655-8700
 深圳总部电话: 0755-28187877
 网址: www.denovocn.com

6-2. ELECTRICAL CHARACTERISTICS
6-2-1. TABLE

Ta = -30 ~ +85°C

Item	FREQUENCY RANGE [MHz]	UNIT	SPECIFICATION		
			Min.	Typ. (25°C)	Max.
Insertion Loss	925 ~ 960	dB	-	1.5	2.3
Inband Ripple	925 ~ 960	dB	-	0.5	1.4
Input VSWR	925 ~ 960	-	-	1.6	2.0
Output VSWR	925 ~ 960	-	-	1.6	2.0
Amplitude Imbalance	925 ~ 960	dB	-1.2	-	+1.2
Phase Imbalance	925 ~ 960	degree	-10	-	+10
Absolute Attenuation	DC ~ 480	dB	45	54	-
	480 ~ 905	dB	25	30	-
	905 ~ 915	dB	15	24	-
	980 ~ 1000	dB	20	25	-
	1000 ~ 1850	dB	22	27	-
	1850 ~ 6000	dB	30	37	-
Termination Impedance		Input: Unbalanced 50 ohm Output: Balanced 150 ohm // 82nH			

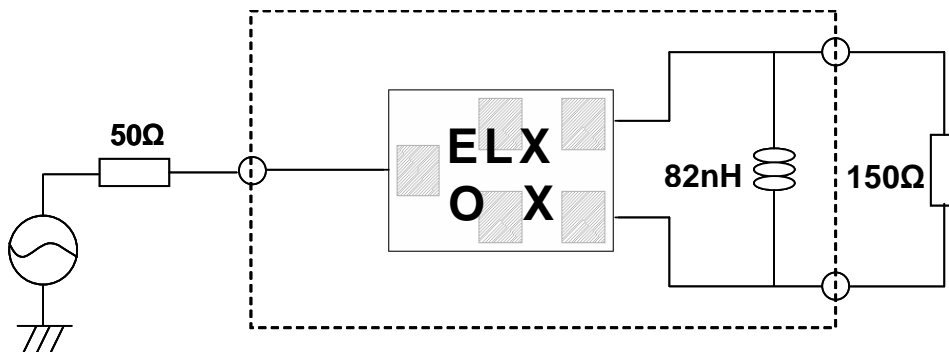
6-2-2. TEST FIXTURE

[X-Ray Top View]

购买原装正品请认准-德方电子
 免费服务热线: 400-655-8700
 深圳总部电话: 0755-28187877
 网址: www.denovocn.com

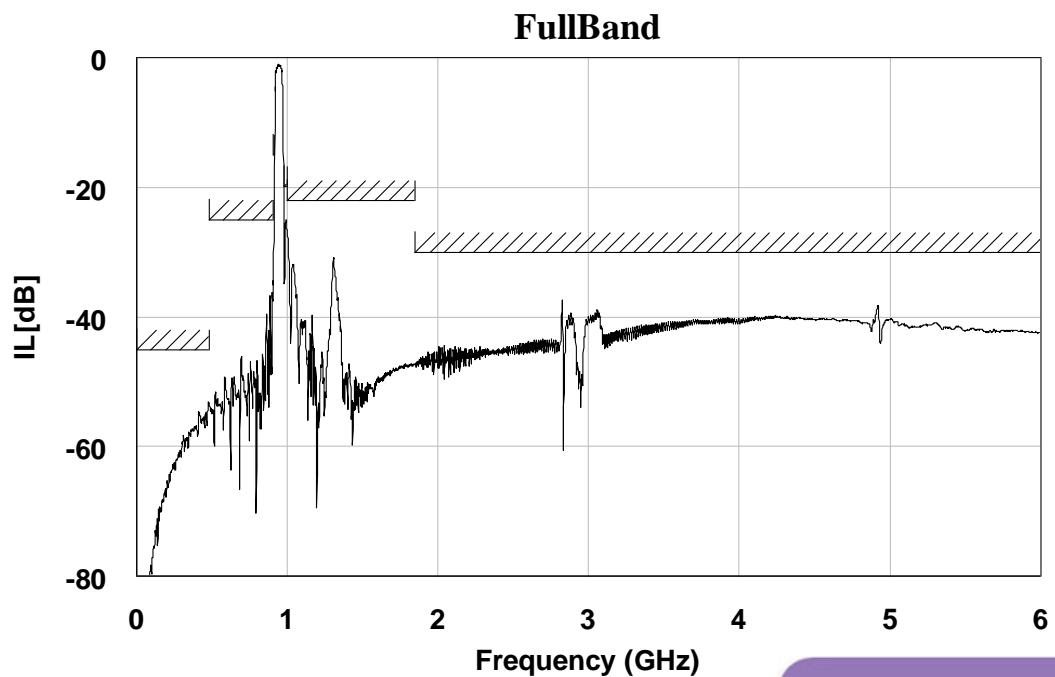
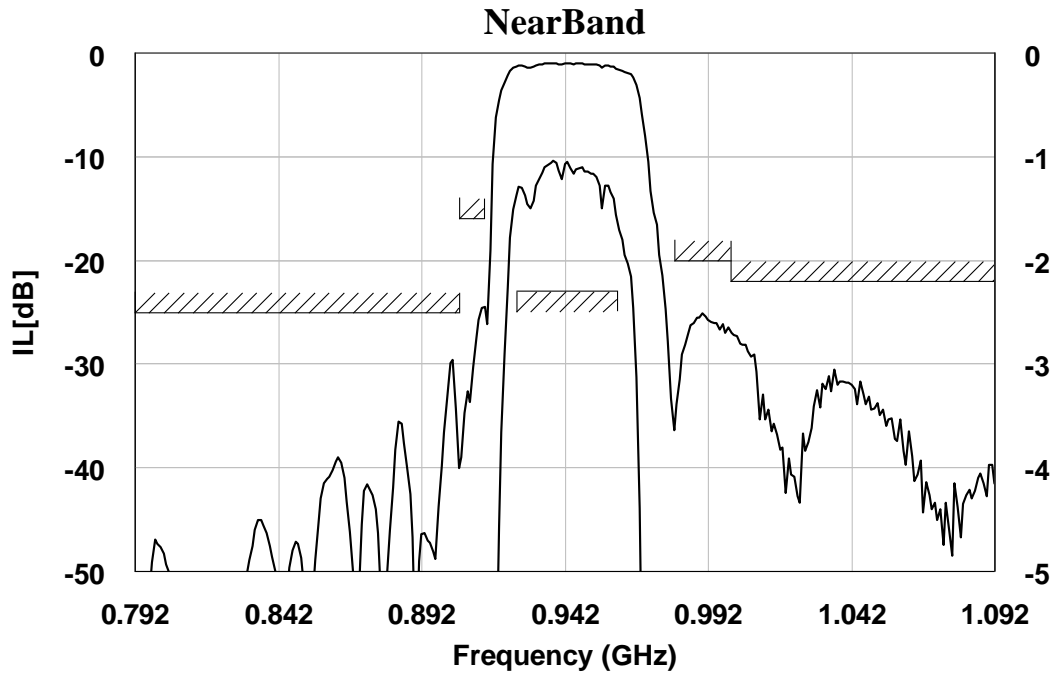
6-2-3. GRAPH



购买原装正品请认准-德方电子
 免费服务热线: 400-655-8700
 深圳总部电话: 0755-28187877
 网址: www.denovocn.com

7. RELIABILITY

7-1. ENGINEERING SAMPLE FLOW CHART

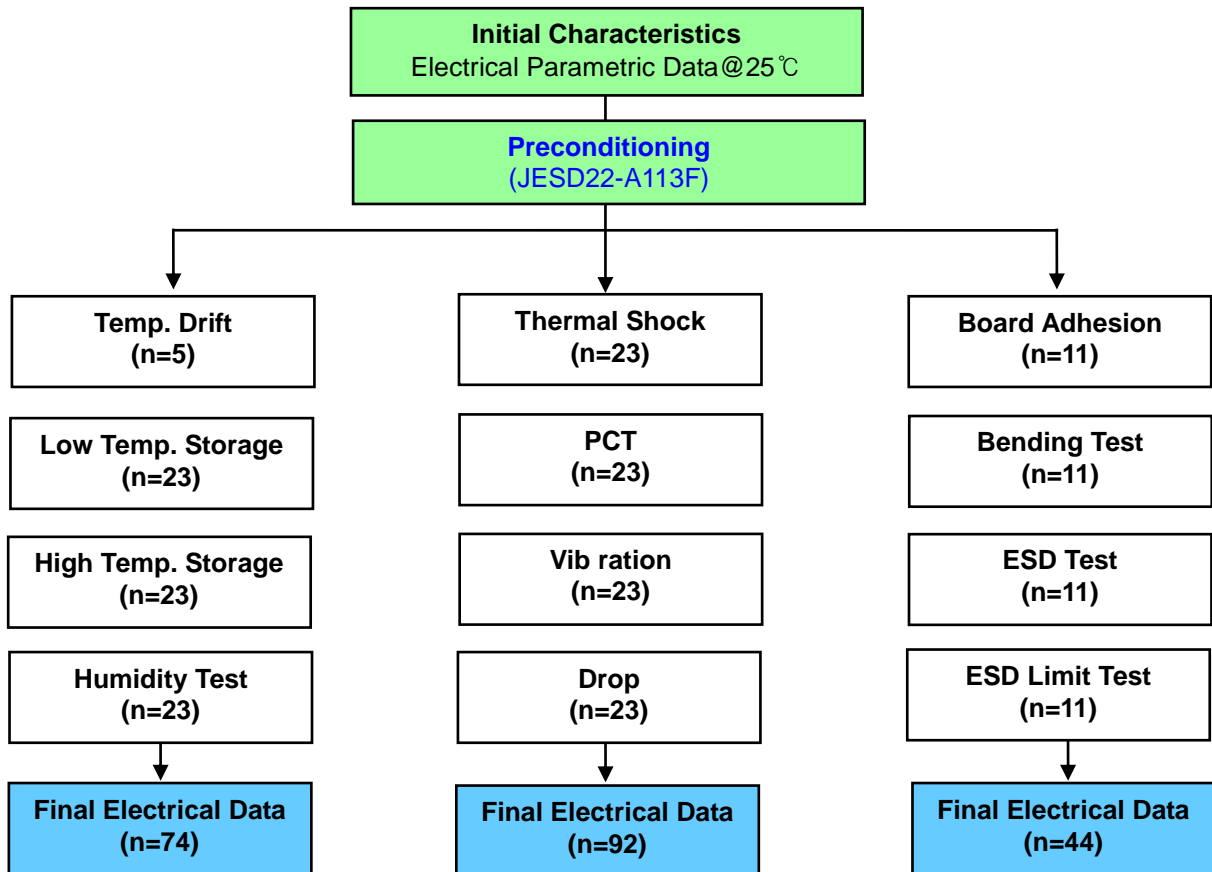

购买原装正品请认准-德方电子
 免费服务热线: 400-655-8700
 深圳总部电话: 0755-28187877
 网址: www.denovocn.com

7-2. TEST ITEM & CONDITION

CATEGORY	TEST ITEM	TEST CONDITION	REMARK
	Preconditioning	+125℃ 24hr Baking → +60℃ 60%RH 120hr → Reflow Test(3times)	JESD22A113F



Environment Test	Temp. Drift	-30℃ → +25℃ → +85℃	description
	High Temp. Storage	+85℃ 240hr	JESD22-A103C
	Low Temp. Storage	-40℃ 240hr	JESD22-A119
	High Temp. High Humidity Storage	+85℃ 85%RH 240hr	JESD22-A106B
	Thermal Shock	-40℃/30min ⇔ +85℃/30min , 100cycle	JESD22-A106A
	High Temp. Operating	+121℃ 100%RH 96hr	JESD22-A102C
Mechanical Test	Vibration Test (Random)	20 Hz~2000 Hz,0.053G ² /Hz or 8g's RMS,15min/plane	IEC 68-2-36 Fdb
	Drop Test	152 cm 12times Steel floor JIG(110g~150g)	IEC 1178-1.4.8.9
	Board Adhesion	0.5 mm/sec 1point push	IEC 68-2-21 Ue3
	Bending Test	0.5 mm/sec 3times -PCB : FR4 , PCB SIZE : 100*40 mm	IEC 68-2-21 Ue3
Physical Test	Solder Heat Resistance	±250V,C=100pF,R=1.5 kΩ,1times	IEC 68-2-21 Ue3
	static marginal test	C=100pF,R=1.5 kΩ,1times(demand of customer)	JESD22-A114F

购买原装正品请认准-德方电子
 免费服务热线: 400-655-8700
 深圳总部电话: 0755-28187877
 网址: www.denovocn.com

8. REFLOW CONDITION

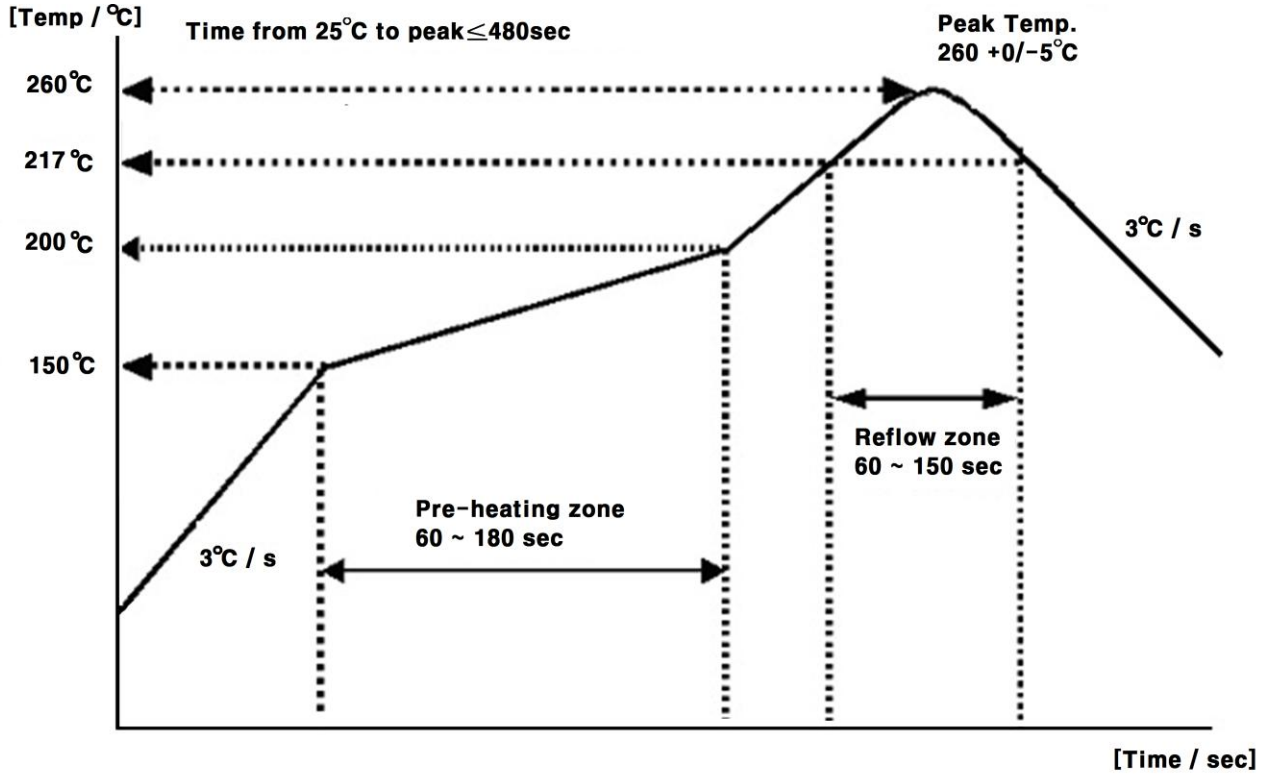

9. RECOMMENDED PCB DIMENSIONS

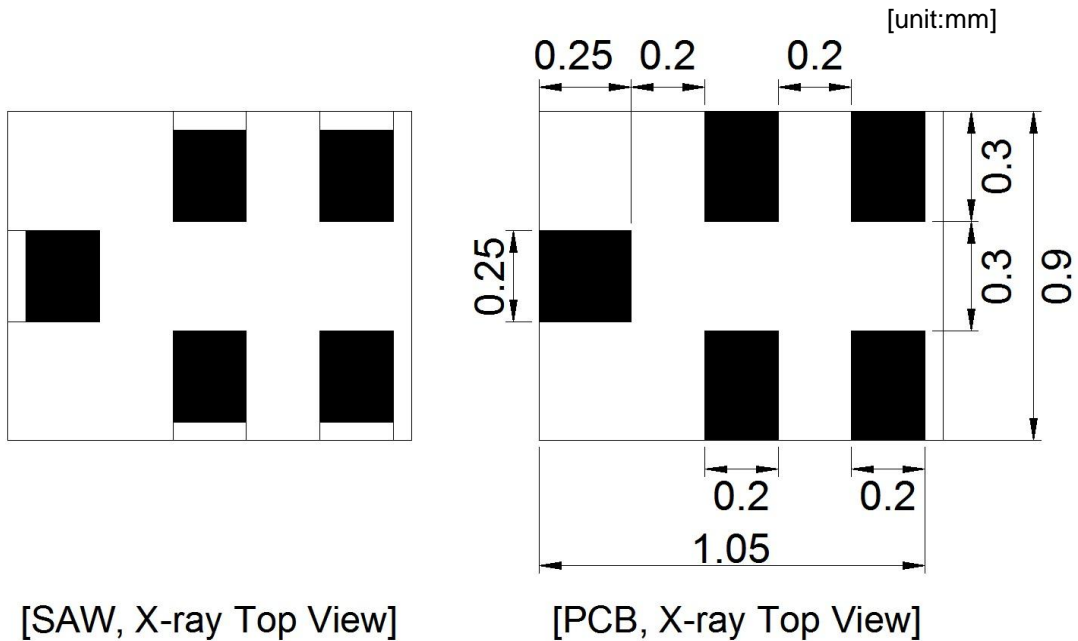

购买原装正品请认准-德方电子
 免费服务热线: 400-655-8700
 深圳总部电话: 0755-28187877
 网址: www.denovocn.com

10. CAUTION

Moisture Sensitivity Device Caution (MSL LEVEL=2a)

1. Calculated shelf life in sealed bag : 12 month at <40℃ and <90% relative Humidity(RH)
 2. Peak package body temperature : **260℃**
 3. After bag is opened, devices that will be subjected to reflow solder or other high temperature process must be
 - (a) Mounted within : 672 hours of factory conditions ≤30℃/60% RH, or
 - (b) Stored per J-STD-033
 4. Device require bake, before mounting, if :
 - (a) Humidity Indicator Card reads > 60% when read at 23±5℃
 - (b) 3(a) or 3(b) are not met
 5. If baking is required, refer to IPC/JEDEC J-STD-033 for bake procedure
- Note : Level and body temperature defined by IPC/JEDEC J-STD-020

Aluminum Pack (310mmX370mm)



HIC(Humidity Indication Card)

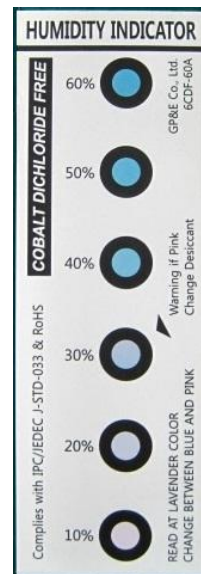

10 to 60% RH

购买原装正品请认准-德方电子
 免费服务热线: 400-655-8700
 深圳总部电话: 0755-28187877
 网址: www.denovocn.com

11. PACKING

11-1. DIMENSIONS

- Carrier Tape

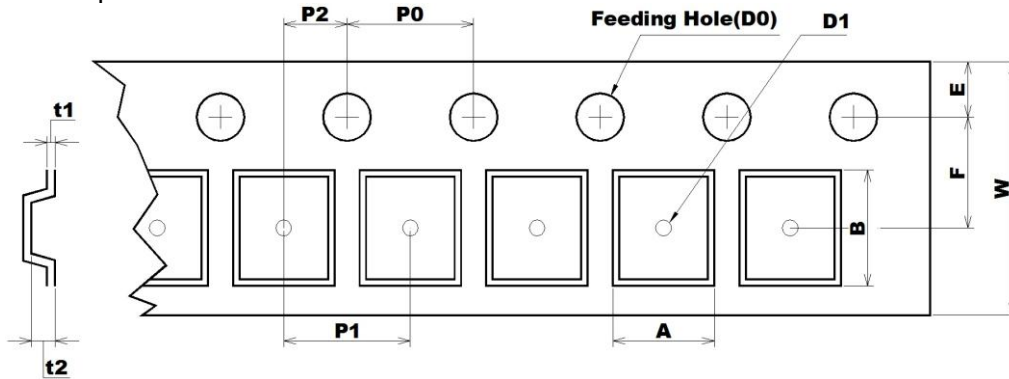

[Unit: mm]

A	B	D0	D1	E	F	P0	P1	P2	t1	t2	W
1.10	1.35	Ø1.50	Ø0.50	1.75	3.50	4.00	4.00	2.00	0.25	0.70	8.00
+0.05	+0.05	+0.10	+0.05	+0.10	+0.05	+0.10	+0.10	+0.05	+0.02	+0.05	+0.30
-0.05	-0.05	-0.00	-0.05	-0.10	-0.05	-0.10	-0.10	-0.05	-0.02	-0.05	-0.10

- Reel

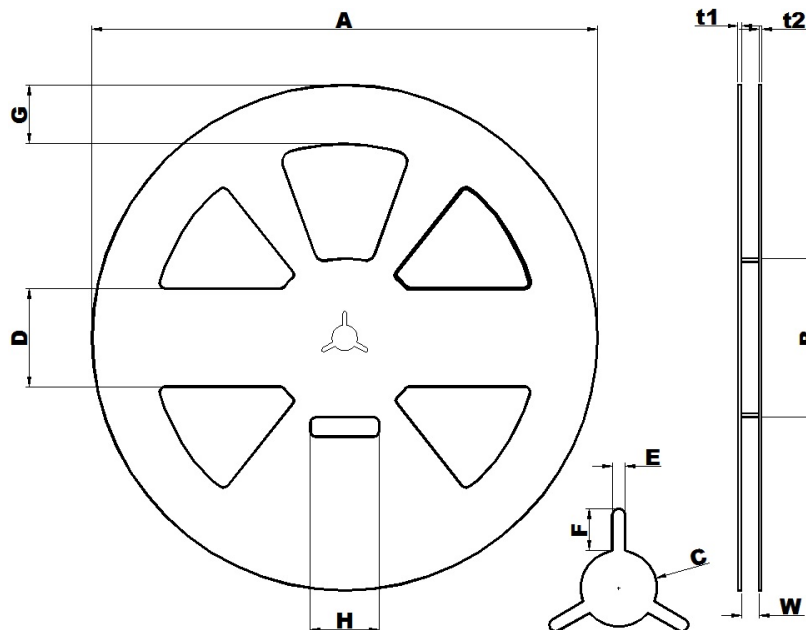

[Unit: mm]

A	B	C	D	E	F	G	H	t1	t2	W
Ø258.0	Ø81.0	Ø13.0	50.0	2.2	7.0	30.0	35.0	1.8	1.5	9.0
+1.0	+1.0	+0.5	+0.8	+0.3	+0.5	+0.8	+1.0	+0.5	+0.5	+1.0
-0.5	-1.0	-0.5	-0.8	-0.3	-0.5	-0.8	-1.0	-0.5	-0.5	-0.5

- The product shall be packed properly not to damaged during transportation and storage.

购买原装正品请认准-德方电子
 免费服务热线: 400-655-8700
 深圳总部电话: 0755-28187877
 网址: www.denovocn.com

11-2. REELING QUANTITY

10 inch reel : 10,000 pcs/reel

11-3. TAPING STRUCTURE

11-3-1. The tape shall be wound around the reel in direction shown below.

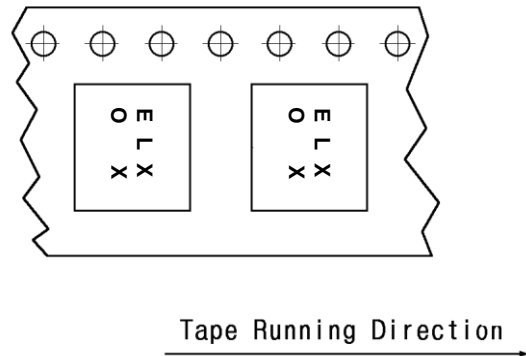
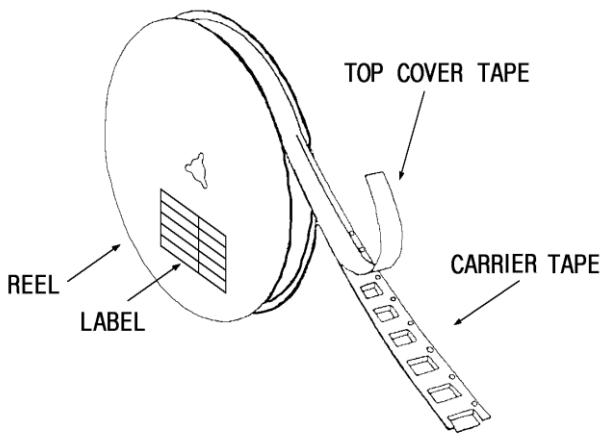

11-3-2. BAR CODE LABEL

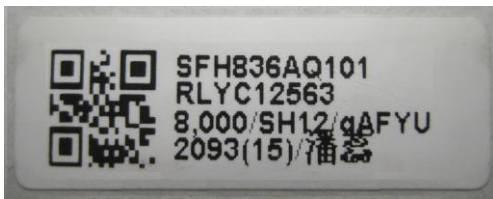

- | | | |
|---|---|--------------------|
| ① |  | MODEL NAME BARCODE |
| ② | SFH836AQ101 | Model Name |
| ③ | RLYC12563 | Reel number |
| ④ | 8000 / qAFYU | Quantity / Marking |

购买原装正品请认准-德方电子
 免费服务热线: 400-655-8700
 深圳总部电话: 0755-28187877
 网址: www.denovocn.com

1-3-3. Leader part and vacant position specifications.

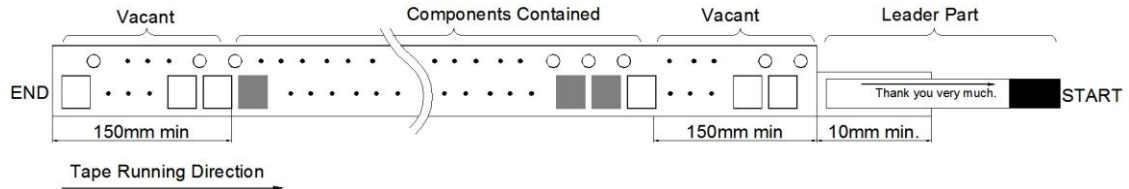

11-4. INNER BOX(Reel Packing) STRUCTURE

Material: Polycarbonate

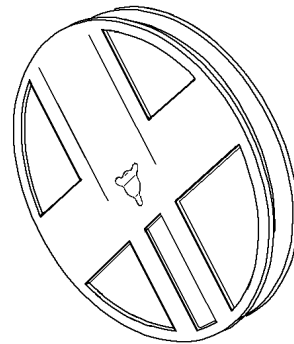

Material: Polyethylene + Aluminium

Size: 310×370mm²

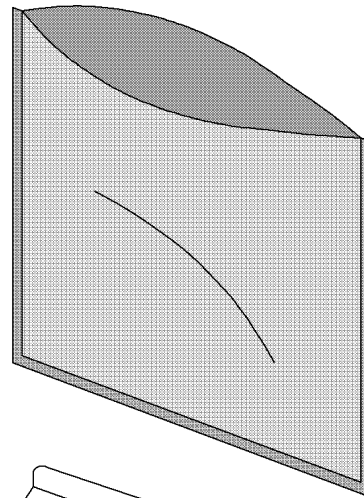

Material: Paper

Size: (D)260×(W)37×(H)265mm³

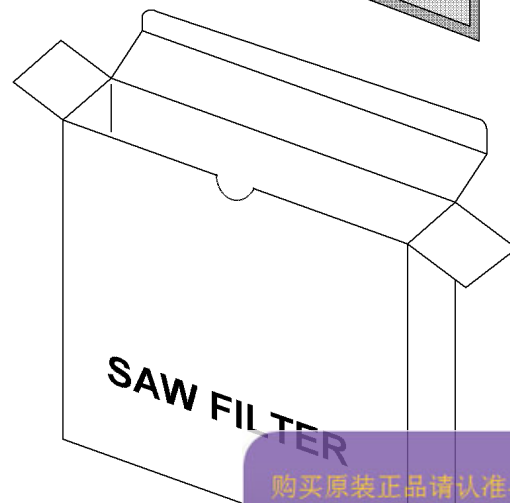

购买原装正品请认准-德方电子
 免费服务热线: 400-655-8700
 深圳总部电话: 0755-28187877
 网址: www.denovocn.com

11-5. OUTER BOX STRUCTURE

Material : Paper

TYPE	SIZE(mm)			Inner Box #
	a	b	c	
A	270	240	275	6 boxes

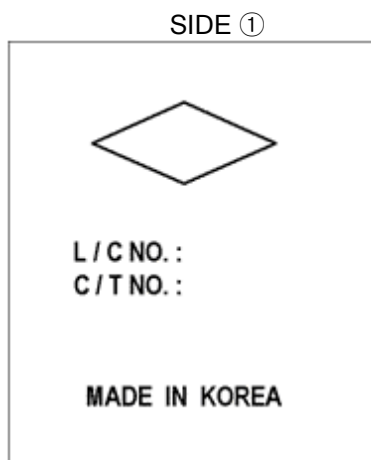
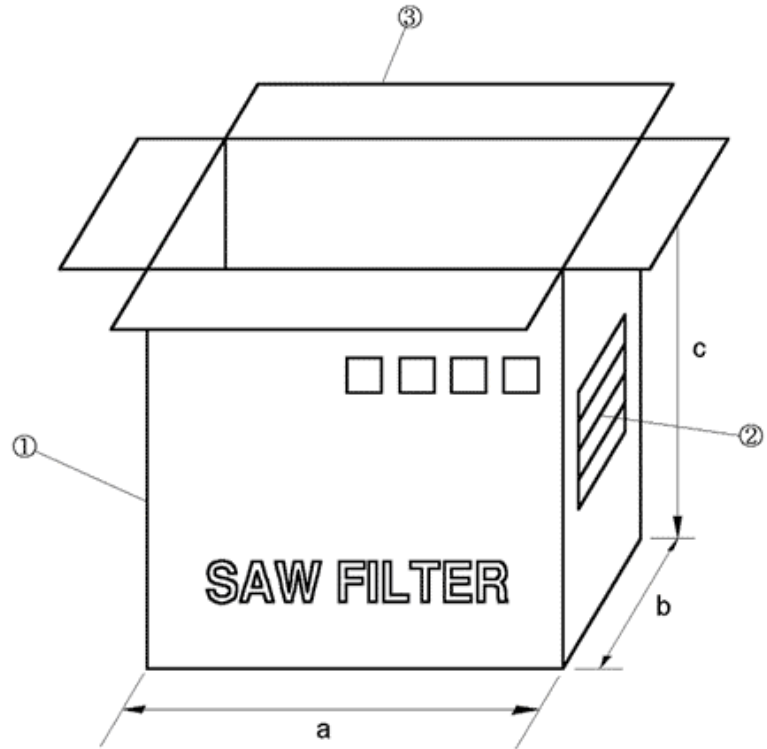

SIDE ②

MODEL	
Q'TY	EA
USER	
DATE	

- SIDE is the same as front side.

购买原装正品请认准-德方电子
 免费服务热线: 400-655-8700
 深圳总部电话: 0755-28187877
 网址: www.denovocn.com

12. TAPE SPECIFICATIONS

12-1. Tensile Strength of Carrier Tape: 4.4N/mm width

12-2. Top Cover Tape Adhesion (See the below figure)

- pull of angle: 0~15 degree
- speed: 300mm/min.
- force: 20~70g

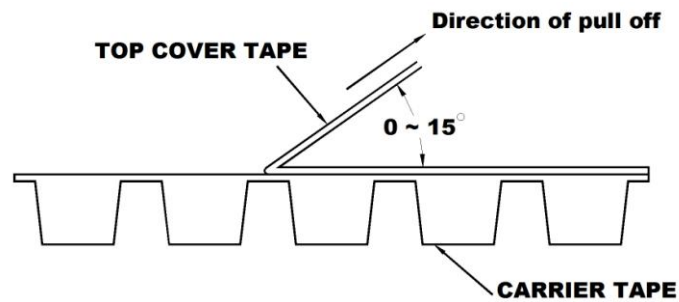

购买原装正品请认准-德方电子
 免费服务热线: 400-655-8700
 深圳总部电话: 0755-28187877
 网址: www.denovocn.com

13. RoHS DATA



Test Report No. F690101/LF-CTSAYAA11-28285

Issued Date: 2011. 09. 06 Page 1 of 2

To: **WISOL CO., LTD.**
373-7
Gajang-dong
Osan-si
Gyeonggi-do
Korea

The following merchandise was submitted and identified by the client as :

SGS File No. : AYAA11-28285
Product Name : SAW FILTER
Item No./Part No. : N/A
Received Date : 2011. 08. 31
Test Period : 2011. 09. 01 to 2011. 09. 06
Test Results : For further details, please refer to following page(s)
Test Performed : SGS Korea tested the sample(s) selected by applicant with following results.
Test Comments : By the applicant's specific request, the sampling and testing was performed only for the part indicated in the photo without disassembly.

SGS Korea Co. Ltd.



Jeff Jang / Chemical Lab Mgr

Timothy Jeon
Jinhee Kim
Cindy Park
Jerry Jung/ Testing Person

This document is issued by the Company subject to its General Conditions of Service printed on request or available at www.sgs.com/terms_and_conditions and, for electronic format documents, subject to Terms and Conditions for Electronic Documents at www.sgs.com/terms_and_conditions_electronic. Attention is drawn to the limitation of liability, indemnification and jurisdiction clause defined therein. Any holder of this document is advised that information contained herein reflects the Company's findings at the time of its issuance only and within the limits of Client's instructions. It may be the Company's sole responsibility as to its Client and this document does not constitute a warranty or other legal obligations under the trademark documents. The document cannot be reproduced except in full without prior written approval of the Company. Any use without identification, forgery or translation of the content or appearance of this document is unlawful and offenders may be prosecuted to the fullest extent of the law. Unless otherwise stated, the results shown in this test report refer only to the sample(s) tested and such sample(s) are retained for 90 days only.

F052 Version4

SGS Korea Co., Ltd.

322, The O valley, 55F-3, Hoge-dong, Dongan-gu, Anyang-si, Gyeonggi-do, Korea 431-080
t +82 (0)31 4608 0000 f +82 (0)31 4608 9559 <http://www.sgslab.co.kr> www.kr.sgs.com/greenlab

Member of the SGS Group (Société Générale de Surveillance)

购买原装正品请认准-德方电子
免费服务热线: 400-655-8700
深圳总部电话: 0755-28187877
网址: www.denovocn.com



Test Report No. F690101/LF-CTSAYAA11-28285

Issued Date: 2011. 09. 06 Page 2 of 2

Sample No. : AYAA11-28285.001
Sample Description : SAW FILTER
Item No./Part No. : N/A
Materials : N/A

Heavy Metals

Test Items	Unit	Test Method	MDL	Results
Antimony (Sb)	mg/kg	With reference to EPA 3052(1996), US EPA 6010B(1996), ICP	10	N.D.

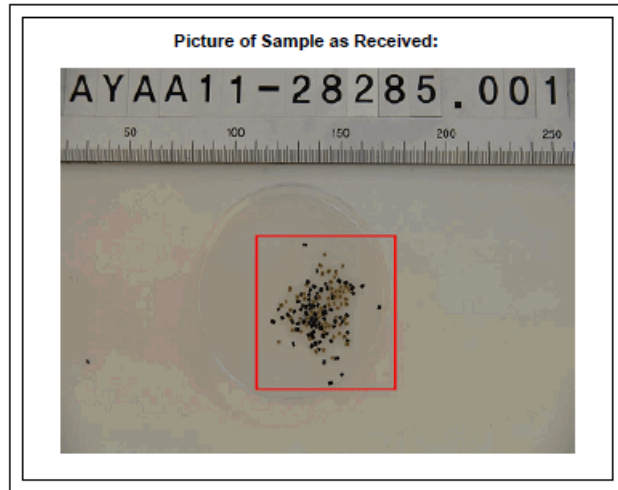

*** End ***

- NOTE: (1) N.D. = Not detected. (<MDL)
 (2) mg/kg = ppm
 (3) MDL = Method Detection Limit
 (4) - = No regulation
 (5) ** = Qualitative analysis (No Unit)
 (6) * = Boiling-water-extraction:
 Negative = Absence of CrVI coating
 Positive = Presence of CrVI coating; the detected concentration in boiling-water-extraction solution is equal or greater than 0.02 mg/kg with 50 cm² sample surface area.

This document is issued by the Company subject to its General Conditions of Service printed hereon, available on request or accessible at www.sgs.com/terms_and_conditions and, for electronic format documents, subject to Terms and Conditions for Electronic Documents at www.sgs.com/terms_e-document.htm. Attention is drawn to the limitation of liability, indemnification and jurisdiction laws defined therein. Any holder of this document is advised that information contained herein reflects the Company's findings at the time of its intervention only and within the limits of Client's instructions. Finally, the Company's sole responsibility is to its Client and this document does not constitute parties to a transaction from evaluating all their rights and obligations under the transaction documents. This document cannot be reproduced, stored in a retrieval system, or transmitted in any form or by any means, without prior written approval of the Company. Any unauthorized alteration, forgery or falsification of the content or appearance of this document is unlawful and offenders may be prosecuted to the fullest extent of the law. Unless otherwise stated the results shown in this test report refer only to the specific tested and each sample(s) are retained for 90 days only.

SGS Korea Co., Ltd.

322, The O valley, 555-9, Hogeje-dong, Dongan-gu, Anyang-si, Gyeonggi-do, Korea 431-080
 t+82 (0)31 4608 000 f+82 (0)31 4608 059 <http://www.sgstab.co.kr> www.kr.sgs.com/greentab

F052 Version4

Member of the SGS Group (Société Générale de Surveillance)

购买原装正品请认准-德方电子
 免费服务热线: 400-655-8700
 深圳总部电话: 0755-28187877
 网址: www.denovocn.com