



SPECIFICATION

Surface Acoustic Wave Filter

USER

USER PART No.

WISOL PART No. **SFH881PA002**

DOC. No. SMS-51-L-SFT-FX-15

DATE August 21, 2012

REVISION 000

WISOL					
	Kim, Kyung-Sik		Hong, Seong-Su		Jeon. Hyeon Cheol
ISSUED BY		APPROVED BY (R&D)		APPROVED BY (QC)	
User					
ISSUED BY		CHECKED BY		APPROVED BY	

WISOL CO., LTD.
 373-7, GAJANG-DONG, OSAN-SI,
 GYUNGGI-DO, KOREA, 447-210
<http://www.wisol.co.kr>

购买原装正品请认准-德方电子
 免费服务热线: 400-655-8700
 深圳总部电话: 0755-28187877
 网址: www.denovocn.com

▶ A TABLE OF CONTENTS

1. REVISION HISTORY	3
2. DEFINITION	4
3. PRECAUTIONS	4
4. OUTLINE DRAWING & DIMENSIONS	5
5. MARKING	6
6. PERFORMANCE	7
6-1. MAXIMUM RATINGS.....	7
6-2. ELECTRICAL CHARACTERISTICS.....	7
7. RELIABILITY	9
7-1. ENGINEERING SAMPLE FLOW CHART	9
7-2. TEST ITEM & CONDITION.....	10
8. REFLOW CONDITION	11
9. RECOMMENDED PCB DIMENSIONS	11
10. CAUTION	12
11. PACKING	13
11-1. DIMENSIONS	13
11-2. REELING QUANTITY	14
11-3. TAPING STRUCTURE	14
11-4. INNER BOX(Reel Packing) STRUCTURE	15
11-5. OUTER BOX STRUCTURE.....	16
12. TAPE SPECIFICATIONS	17
13. RoHS DATA	18

购买原装正品请认准-德方电子
 免费服务热线: 400-655-8700
 深圳总部电话: 0755-28187877
 网址: www.denovocn.com

1. REVISION HISTORY

000	AUG 21, 2012	All page	Make specification
-----	--------------	----------	--------------------

购买原装正品请认准-德方电子
免费服务热线: 400-655-8700
深圳总部电话: 0755-28187877
网址: www.denovocn.com

2. DEFINITION

2-1. PART No.

S F H 881 P A0 02

① ② ③ ④ ⑤ ⑥

NO.	EXPLANATION
①	SAW Filter
②	Design Type
③	Center Frequency: 881.5MHz(869 ~ 894)
④	Input:50ohm,Output:150ohm
⑤	Package size : 1.1×0.9mm ²
⑥	Design Revision (02 : Molding Type)

2-2. APPLICATION : Band-Pass Filter for CDAM Rx etc (UMTS Band V)

3. PRECAUTIONS

3-1. This device should not be used in any type of fluid such as water, oil, organic solvent, etc.

3-2. This is a hermetic device.

MSL(Moisture Sensitive Level) is the '2a' level.

3-3. Ultrasonic cleaning shall be avoided.

3-4. Isopropyl Alcohol and Ethyl Alcohol can be used for cleaning. Contact us before using other cleaning solvents than above

3-5. This is an electrostatic sensitive device.

Please avoid static voltage during operation and storage.

3-6. Sudden change of temperature shall be avoided, deterioration of the characteristics can occur.

3-7. If any malfunction due to designing or manufacturing which is out of specification occurs within one year after the products have been delivered, the maker should exchange the defective products.

购买原装正品请认准-德方电子
 免费服务热线: 400-655-8700
 深圳总部电话: 0755-28187877
 网址: www.denovocn.com

4. OUTLINE DRAWING & DIMENSIONS

[Unit: mm]

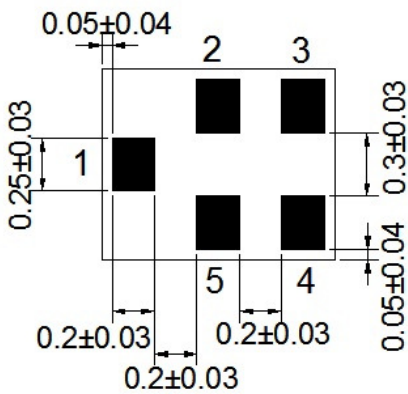
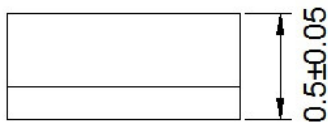
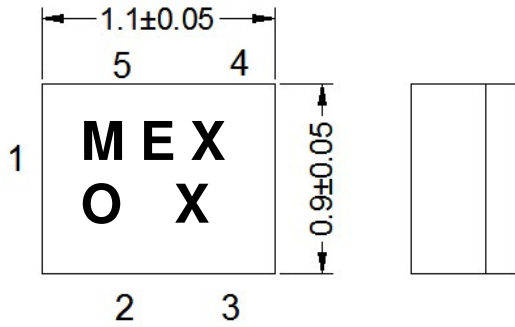

No.	Function
2, 5	Ground
1	Unbalanced Input
3,4	Balanced Output

购买原装正品请认准-德方电子
 免费服务热线: 400-655-8700
 深圳总部电话: 0755-28187877
 网址: www.denovocn.com

5. MARKING



5-1. MEXX

- The 1st, 2nd character 'ME' indicates the model name of SAW Filter “SFH881PA002” .
- The 3rd character 'X' indicates the year and the month of manufacture.

Year	Month											
	1	2	3	4	5	6	7	8	9	10	11	12
2013	P	Q	R	S	T	U	V	W	X	Y	Z	a
2014	1	2	3	4	5	6	7	8	9	A	B	C
2015	D	E	F	G	H	I	J	K	L	M	N	O
2016	P	Q	R	S	T	U	V	W	X	Y	Z	a

※ This rotates by the 3 years.

- The 4th character 'X' indicates day of manufacture.

5-2. ○

- This symbol indicates input pin 1.
- This indicates the producing center
○: China

5-3. Marking: Laser Marking

购买原装正品请认准-德方电子
 免费服务热线: 400-655-8700
 深圳总部电话: 0755-28187877
 网址: www.denovcn.com

6. PERFORMANCE

6-1. MAXIMUM RATINGS

CHARACTERISTICS	RATINGS	UNITS
DC Permissive Voltage	5	V
Maximum Input Power	15	dBm
Operating Temperature Range	- 30 ~ +85	℃
Storage Temperature Range	- 40 ~ +85	℃

6-2. ELECTRICAL CHARACTERISTICS

6-2-1. TABLE

Ta = - 30 ~ +85℃

Item	FREQUENCY RANGE [MHz]	UNIT	SPECIFICATION		
			Min.	Typ. (25℃)	Max.
Insertion Loss	869 ~ 894	dB	-	1.1	1.6
Inband Ripple	869 ~ 894	dB	-	0.3	1.0
Input VSWR	869 ~ 894	-	-	1.6	2.0
Output VSWR	869 ~ 894	-	-	1.6	2.0
Amplitude Imbalance	869 ~ 894	dB	-1.0	-	+1.0
Phase Imbalance	869 ~ 894	degree	-5	-	+5
Absolute Attenuation	DC ~ 447	dB	40	50	-
	447 ~ 849	dB	26	29	-
	915 ~ 960	dB	13	18	-
	960 ~ 3000	dB	25	30	-
	3000 ~ 6000	dB	33	41	-
Termination Impedance		Input: Unbalanced 50 ohm Output: Balanced 150 ohm // 68nH			

6-2-2. TEST FIXTURE

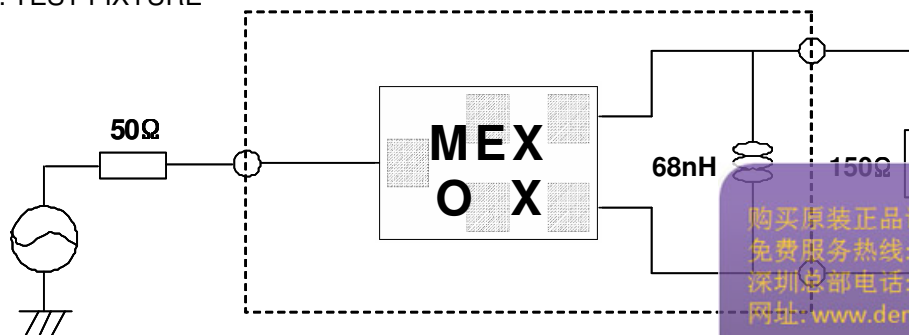

< X-ray Top View >

购买原装正品请认准-德方电子
 免费服务热线: 400-655-8700
 深圳总部电话: 0755-28187877
 网址: www.denovocn.com

6-2-3. GRAPH

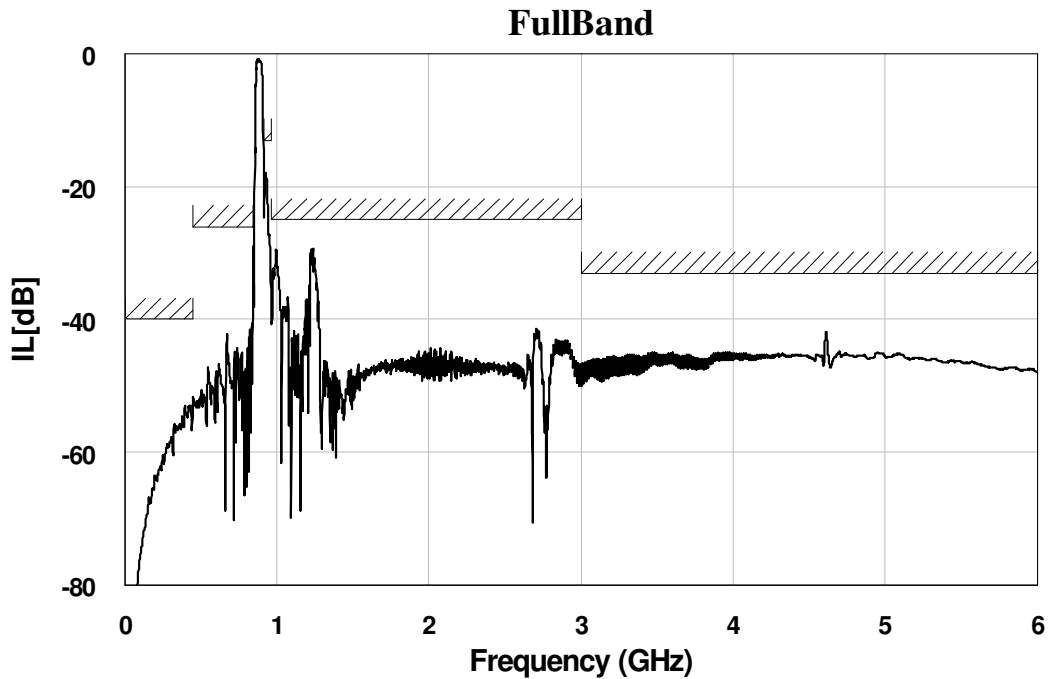
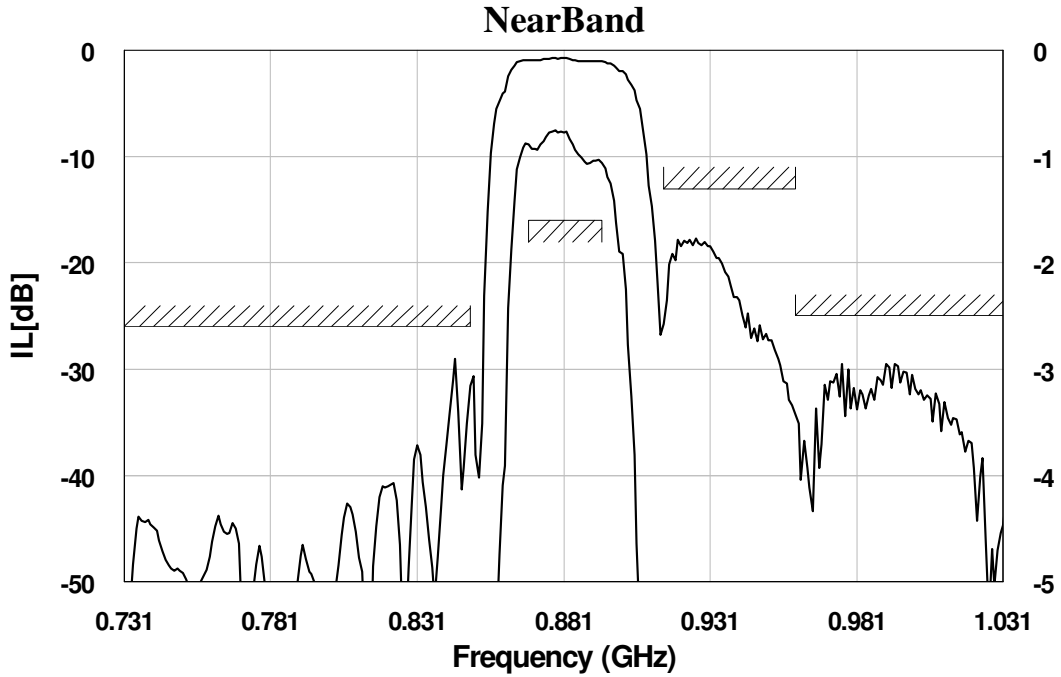

购买原装正品请认准-德方电子
 免费服务热线: 400-655-8700
 深圳总部电话: 0755-28187877
 网址: www.denovocn.com

7. RELIABILITY

7-1. ENGINEERING SAMPLE FLOW CHART

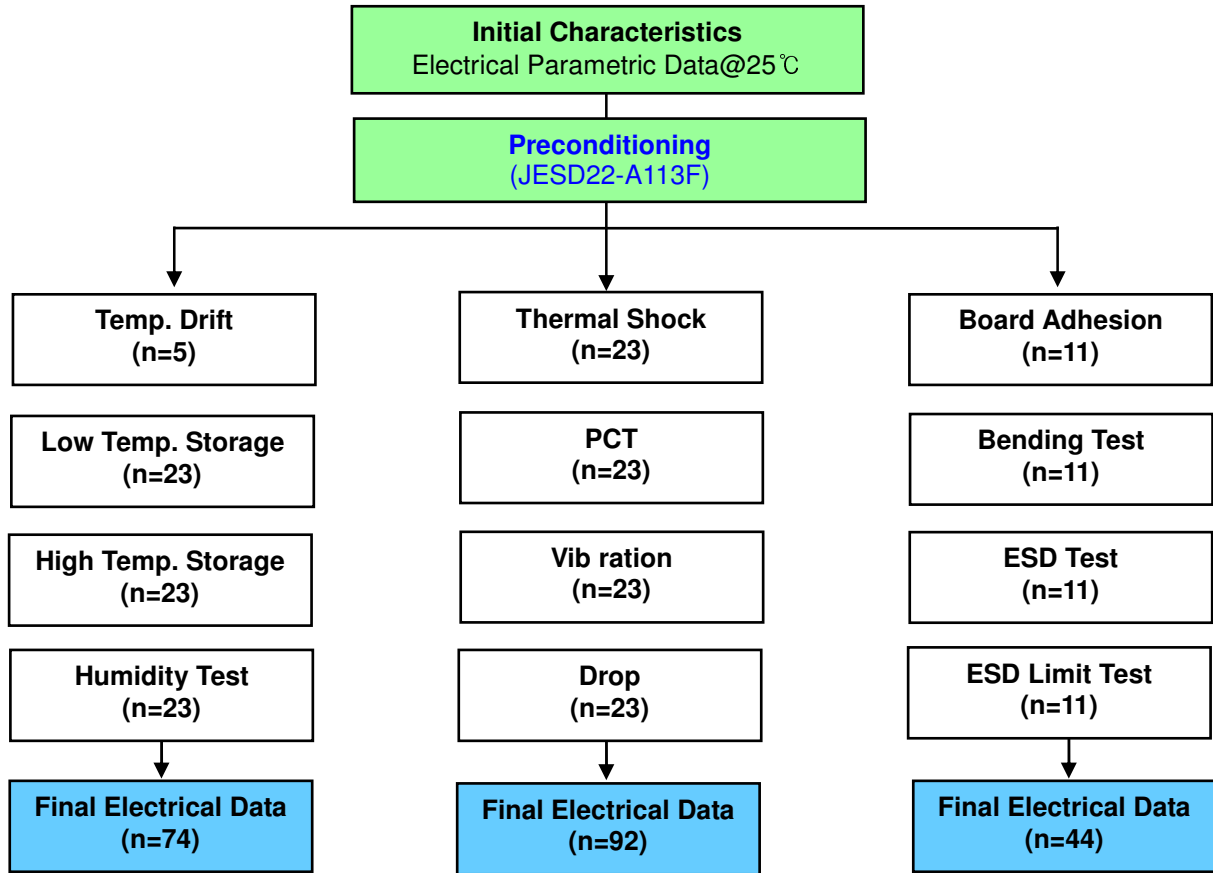

购买原装正品请认准-德方电子
 免费服务热线: 400-655-8700
 深圳总部电话: 0755-28187877
 网址: www.denovocn.com

7-2. TEST ITEM & CONDITION

CATEGORY	TEST ITEM	TEST CONDITION	REMARK
	Preconditioning	+125℃ 24hr Baking → +60℃ 60%RH 120hr → Reflow Test(3times)	JESD22A113F



Environment Test	Temp. Drift	-30℃ → +25℃ → +85℃	description
	High Temp. Storage	+85℃ 240hr	JESD22-A103C
	Low Temp. Storage	-40℃ 240hr	JESD22-A119
	High Temp. High Humidity Storage	+85℃ 85%RH 240hr	JESD22-A106B
	Thermal Shock	-40℃/30min ⇔ +85℃/30min , 100cycle	JESD22-A106A
	High Temp. Operating	+121℃ 100%RH 96hr	JESD22-A102C
Mechanical Test	Vibration Test (Random)	20 Hz~2000 Hz,0.053G ² /Hz or 8g's RMS,15min/plane	IEC 68-2-36 Fdb
	Drop Test	152 cm 12times Steel floor JIG(110g~150g)	IEC 1178-1.4.8.9
	Board Adhesion	0.5 mm/sec 1point push	IEC 68-2-21 Ue3
	Bending Test	0.5 mm/sec 3times -PCB : FR4 , PCB SIZE : 100*40 mm	IEC 68-2-21 Ue3
Physical Test	Solder Heat Resistance	±250V,C=100pF,R=1.5 kΩ,1times	IEC 68-2-21 Ue3
	static marginal test	C=100pF,R=1.5 kΩ,1times(demand of customer)	JESD22-A114F

购买原装正品请认准-德方电子
 免费服务热线: 400-655-8700
 深圳总部电话: 0755-28187877
 网址: www.denovocn.com

8. REFLOW CONDITION

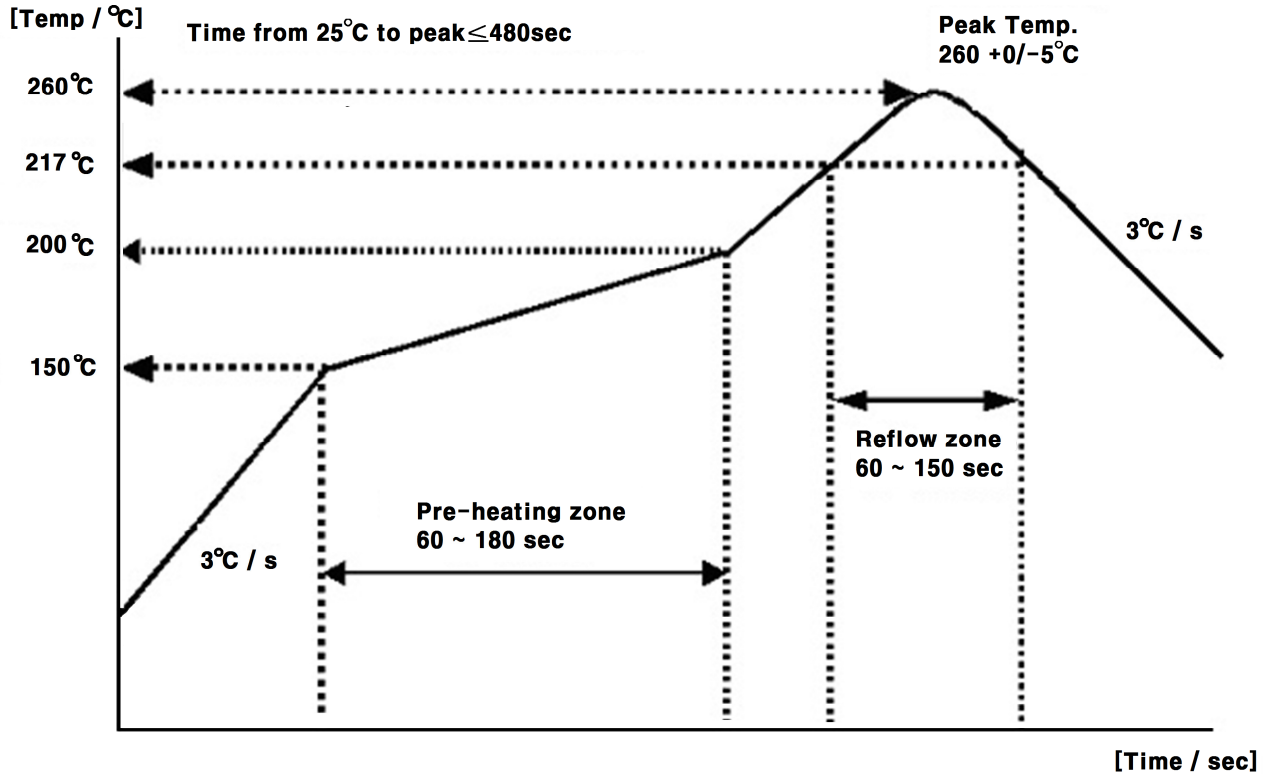

9. RECOMMENDED PCB DIMENSIONS

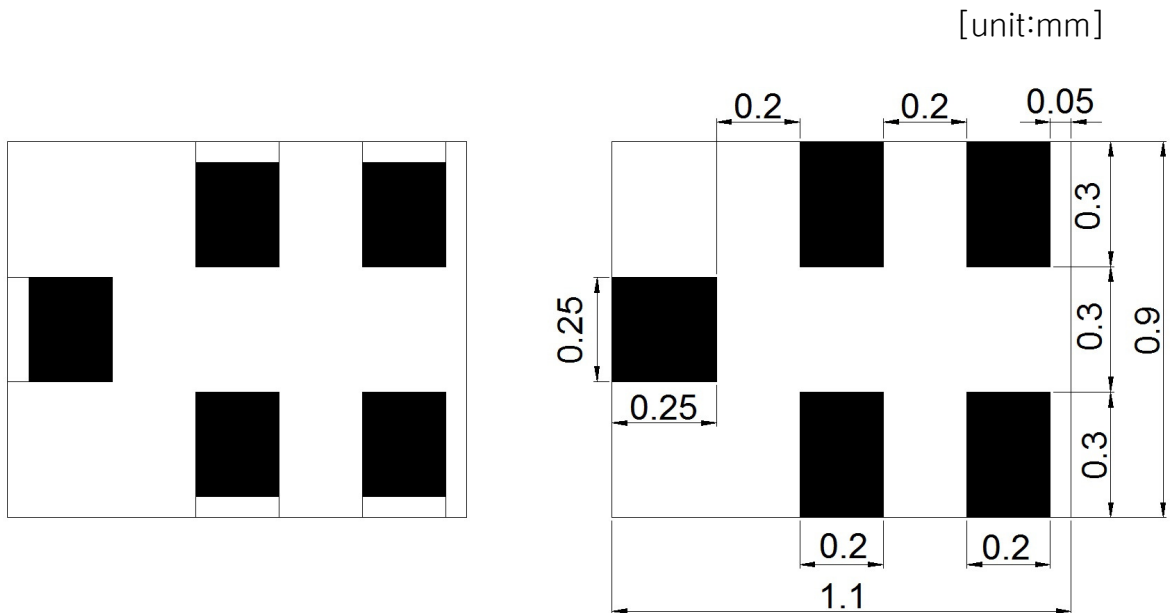

[SAW, X-ray Top view]

[PCB, X-ray Top view]

购买原装正品请认准-德方电子
 免费服务热线: 400-655-8700
 深圳总部电话: 0755-28187877
 网址: www.denovcn.com

10. CAUTION

Moisture Sensitivity Device Caution (MSL LEVEL=2a)

1. Calculated shelf life in sealed bag : 12 month at < 40°C and < 90% relative Humidity(RH)
 2. Peak package body temperature : **260°C**
 3. After bag is opened, devices that will be subjected to reflow solder or other high temperature process must be
 - (a) Mounted within : 672 hours of factory conditions ≤30°C/60% RH, or
 - (b) Stored per J-STD-033
 4. Device require bake, before mounting, if :
 - (a) Humidity Indicator Card reads > 60% when read at 23±5°C
 - (b) 3(a) or 3(b) are not met
 5. If baking is required, refer to IPC/JEDEC J-STD-033 for bake procedure
- Note : Level and body temperature defined by IPC/JEDEC J-STD-020

Aluminum Pack (310mmX370mm)



HIC(Humidity Indication Card)

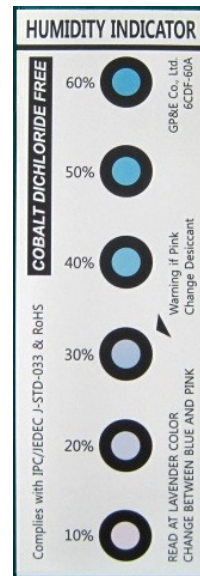

10 to 60% RH

购买原装正品请认准-德方电子
 免费服务热线: 400-655-8700
 深圳总部电话: 0755-28187877
 网址: www.denovocn.com

11. PACKING
11-1. DIMENSIONS

- Carrier Tape

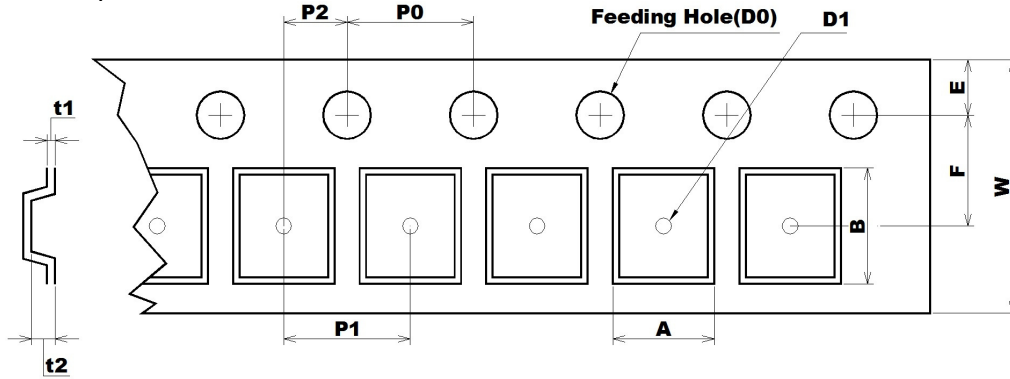

[Unit: mm]

A	B	D0	D1	E	F	P0	P1	P2	t1	t2	W
1.1	1.35	Ø1.50	Ø0.50	1.75	3.50	4.00	4.00	2.00	0.25	0.70	8.00
0.05	0.05	+0.10 -0.00	0.05	0.10	0.05	0.10	0.10	0.05	0.02	0.07	+0.30 -0.10

- Reel

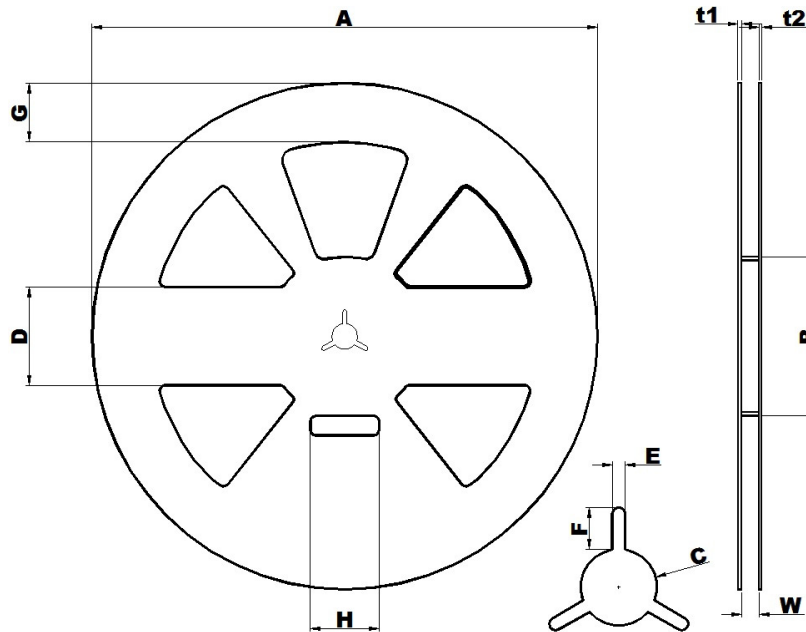

[Unit: mm]

A	B	C	D	E	F	G	H	t1	t2	W
Ø258.0	Ø81.0	Ø13.0	50.0	2.2	7.0	30.0	35.0	1.8	1.5	9.0
+1.0	+1.0	+0.5	+0.8	+0.3	+0.5	+0.8	+1.0	+0.5	+0.5	+1.0
-0.5	-1.0	-0.5	-0.8	-0.3	-0.5	-0.8	-1.0	-0.5	-0.5	-0.5

- The product shall be packed properly not to damaged during transportation and storage.

 购买原装正品请认准-德力电子
 免费服务热线: 400-655-8700
 深圳总部电话: 0755-28187877
 网址: www.denovcn.com

11-2. REELING QUANTITY

10 inch reel : 10,000 pcs/reel

11-3. TAPING STRUCTURE

11-3-1. The tape shall be wound around the reel in direction shown below.

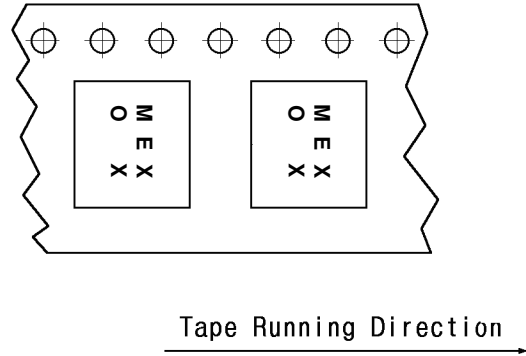
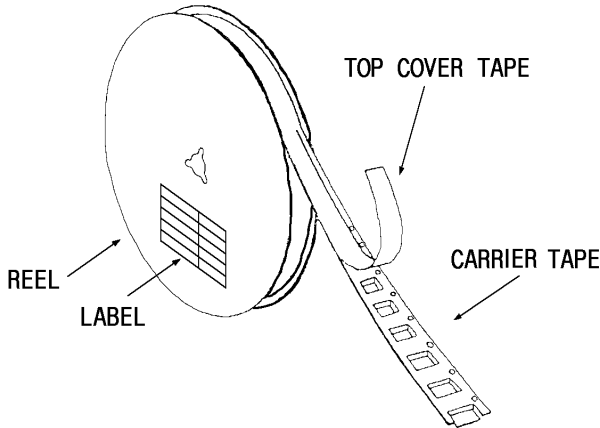

11-3-2. BAR CODE LABEL

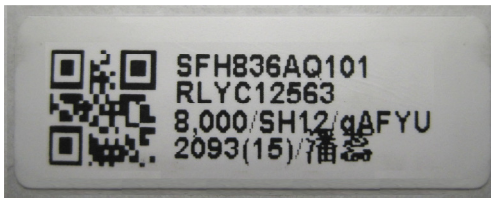

①



MODEL NAME BARCODE

②

SFH836AQ101

Model Name

③

RLYC12563

Reel number

④

8000 / qAFYU

Quantity / Marking

购买原装正品请认准-德方电子
免费服务热线: 400-655-8700
深圳总部电话: 0755-28187877
网址: www.denovocn.com

1-3-3. Leader part and vacant position specifications.

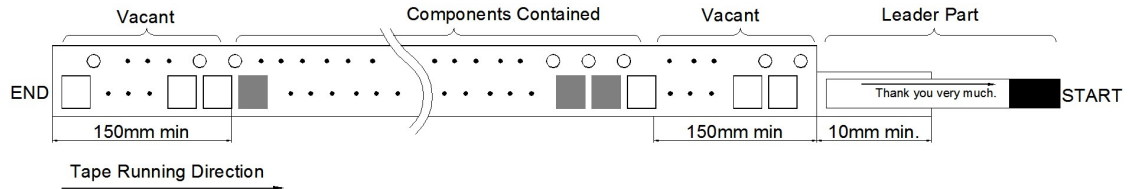

11-4. INNER BOX(Reel Packing) STRUCTURE

Material: Polycarbonate

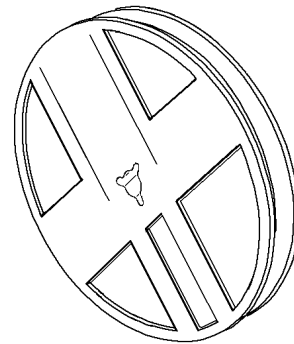

Material: Polyethylene + Aluminium
Size: 310×370mm²

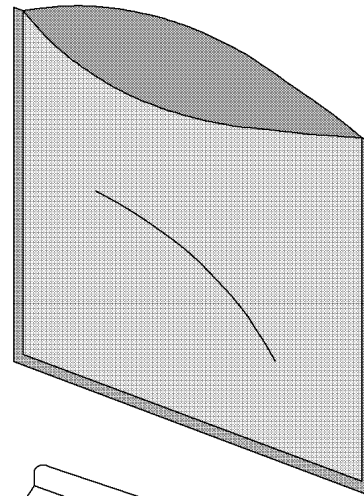

Material: Paper
Size: (D)260×(W)37×(H)265mm³

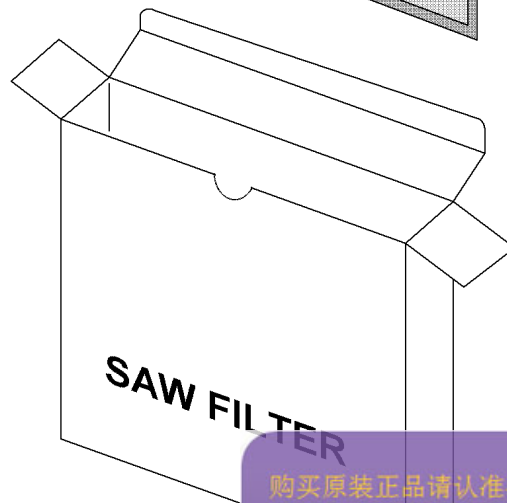

购买原装正品请认准-德方电子
免费服务热线: 400-655-8700
深圳总部电话: 0755-28187877
网址: www.denovocn.com

11-5. OUTER BOX STRUCTURE

Material : Paper

TYPE	SIZE(mm)			Inner Box #
	a	b	c	
A	270	240	275	6 boxes

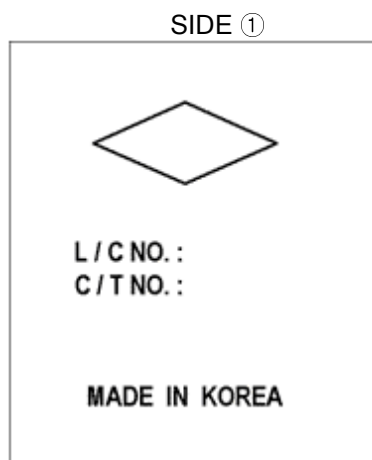
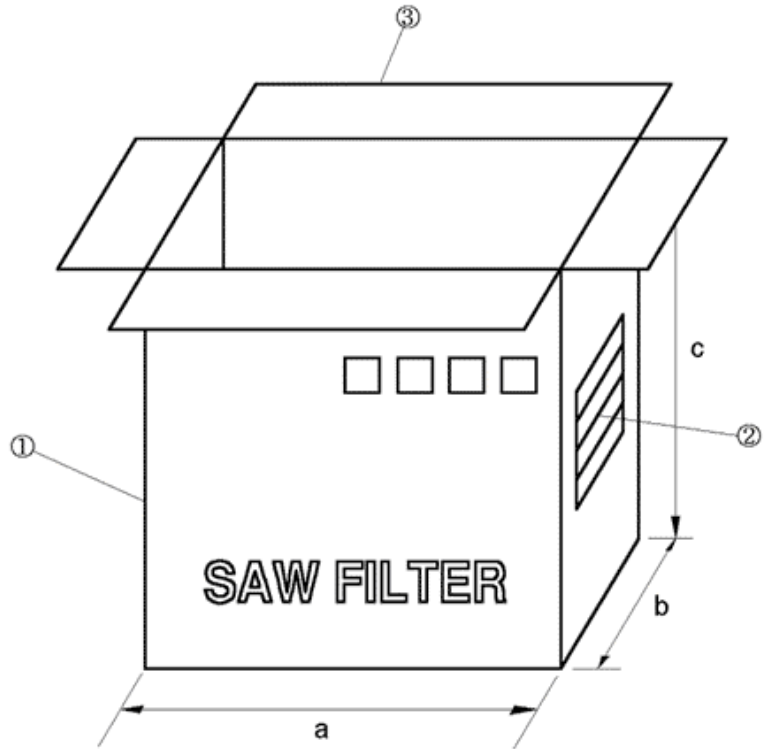

SIDE ②

MODEL	
Q'TY	EA
USER	
DATE	

- SIDE is the same as front side.

购买原装正品请认准-德方电子
免费服务热线: 400-655-8700
深圳总部电话: 0755-28187877
网址: www.denovocn.com

12. TAPE SPECIFICATIONS

12-1. Tensile Strength of Carrier Tape: 4.4N/mm width

12-2. Top Cover Tape Adhesion (See the below figure)

- pull of angle: 0~15 degree
- speed: 300mm/min.
- force: 20~70g

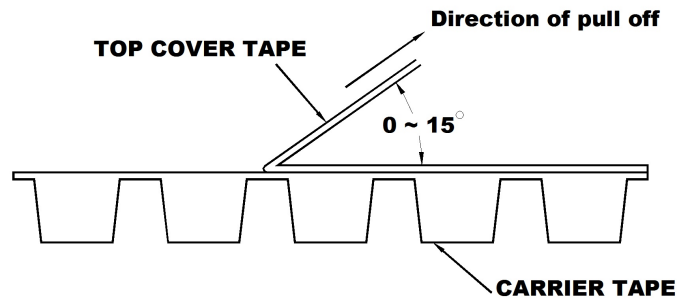

购买原装正品请认准-德方电子
 免费服务热线: 400-655-8700
 深圳总部电话: 0755-28187877
 网址: www.denovocn.com

13. RoHS DATA



Test Report No. F690101/LF-CTSAYAA13-31939

Issued Date: 2013. 07. 08 Page 1 of 6

To: **WISOL CO., LTD.**
373-7
Gajang-dong
Osan-si
Gyeonggi-do
Korea

The following merchandise was submitted and identified by the client as :

SGS File No. : AYAA13-31939
Product Name : SAW FILTER
Item No./Part No. : N/A
Received Date : 2013. 07. 03
Test Period : 2013. 07. 04 to 2013. 07. 08
Buyer(s) : SAMSUNG
Test Results : For further details, please refer to following page(s)
Test Performed : SGS Korea tested the sample(s) selected by applicant with following results.
Test Comments : By the applicant's specific request, the sampling and testing was performed only for the part indicated in the photo without disassembly.

Timothy Jeon
Jinhee Kim
Cindy Park
Jerry Jung/ Testing Person

SGS Korea Co., Ltd.



Jeff Jang / Chemical Lab Mgr

Document is issued by the Company subject to its General Conditions of Service printed hereon, available on request or accessible at <http://www.sgs.com/ClientandConditions.aspx> and, for electronic format documents, subject to Terms and Conditions for Electronic Documents at <http://www.sgs.com/ClientandConditions.aspx>. Attention is drawn to the limitation of liability, indemnification and jurisdiction issues defined therein. Any issue of the document is subject to the information contained herein reflects the Company's findings at the time of its intervention only and within the limits of Client's instructions. The Company's sole responsibility is to the Client and the document does not constitute parties to a transaction from examining all their rights and obligations under the transaction documents. This document cannot be reproduced, stored in a retrieval system, or transmitted in any form or by any means, electronic, mechanical, photocopying, recording, or by any information storage and retrieval system, without prior written approval of the Company. Any unauthorized alteration, modification or suppression of the content of this document is unlawful and offenders may be prosecuted to the fullest extent of the law. All references herein to the results shown in this test report refer only to the sample(s) tested and each sample(s) are retained for 90 days only.

SGS Korea Co., Ltd.

322, The O valley, 555-0, Hoge-dong, Dongen-gu, Anyang-si, Gyeonggi-do, Korea 431-080
t +82 (0)31 4808 000 f +82 (0)31 4808 050 <http://www.sgs.com> www.kr.sgs.com/greenlab

052 Version5

Member of the SGS Group (Société Générale de Surveillance)

购买原装正品请认准-德方电子
免费服务热线: 400-655-8700
深圳总部电话: 0755-28187877
网址: www.denovocn.com

Test Report No. F690101/LF-CTSAYAA13-31939

Issued Date: 2013. 07. 08 Page 2 of 8

Sample No. : AYAA13-31939.001
Sample Description : SAW FILTER
Item No./Part No. : N/A
Materials : N/A

Heavy Metals

Test Items	Unit	Test Method	MDL	Results
Cadmium (Cd)	mg/kg	With reference to IEC 62321:2008, ICP	0.5	N.D.
Lead (Pb)	mg/kg	With reference to IEC 62321:2008, ICP	5	N.D.
Mercury (Hg)	mg/kg	With reference to IEC 62321:2008, ICP	2	N.D.
Hexavalent Chromium (Cr VI)	mg/kg	With reference to IEC 62321:2008, UV-VIS	1	N.D.
Antimony (Sb)	mg/kg	With reference to EPA 3052(1996), US EPA 6010B(1996), ICP	10	N.D.

Flame Retardants-PBBs/PBDEs

Test Items	Unit	Test Method	MDL	Results
Monobromobiphenyl	mg/kg	With reference to IEC 62321:2008, GC-MS	5	N.D.
Dibromobiphenyl	mg/kg	With reference to IEC 62321:2008, GC-MS	5	N.D.
Tribromobiphenyl	mg/kg	With reference to IEC 62321:2008, GC-MS	5	N.D.
Tetrabromobiphenyl	mg/kg	With reference to IEC 62321:2008, GC-MS	5	N.D.
Pentabromobiphenyl	mg/kg	With reference to IEC 62321:2008, GC-MS	5	N.D.
Hexabromobiphenyl	mg/kg	With reference to IEC 62321:2008, GC-MS	5	N.D.
Heptabromobiphenyl	mg/kg	With reference to IEC 62321:2008, GC-MS	5	N.D.
Octabromobiphenyl	mg/kg	With reference to IEC 62321:2008, GC-MS	5	N.D.
Nonabromobiphenyl	mg/kg	With reference to IEC 62321:2008, GC-MS	5	N.D.
Decabromobiphenyl	mg/kg	With reference to IEC 62321:2008, GC-MS	5	N.D.
Monobromodiphenyl ether	mg/kg	With reference to IEC 62321:2008, GC-MS	5	N.D.
Dibromodiphenyl ether	mg/kg	With reference to IEC 62321:2008, GC-MS	5	N.D.
Tribromodiphenyl ether	mg/kg	With reference to IEC 62321:2008, GC-MS	5	N.D.
Tetrabromodiphenyl ether	mg/kg	With reference to IEC 62321:2008, GC-MS	5	N.D.
Pentabromodiphenyl ether	mg/kg	With reference to IEC 62321:2008, GC-MS	5	N.D.
Hexabromodiphenyl ether	mg/kg	With reference to IEC 62321:2008, GC-MS	5	N.D.
Heptabromodiphenyl ether	mg/kg	With reference to IEC 62321:2008, GC-MS	5	N.D.
Octabromodiphenyl ether	mg/kg	With reference to IEC 62321:2008, GC-MS	5	N.D.
Nonabromodiphenyl ether	mg/kg	With reference to IEC 62321:2008, GC-MS	5	N.D.

NOTE:

- (1) N.D. = Not detected. (<MDL)
- (2) mg/kg = ppm
- (3) MDL = Method Detection Limit
- (4) - = No regulation
- (5) Negative = Undetectable / Positive = Detectable
- (6) ** = Qualitative analysis (No Unit)
- (7) * = Boiling-water-extraction:
 Negative = Absence of CrVI coating
 Positive = Presence of CrVI coating; the detected concentration in boiling-water-extraction solution is equal or greater than 0.02 mg/kg with 50 cm² sample surface area.

The document is issued by the Company subject to the General Conditions of Service printed on each order or available at www.sgs.com and to electronic format documents subject to Terms and Conditions for Electronic Documents at www.sgs.com/conditions. However it does not constitute a contract. Any holder of the document is advised that information contained herein reflects the Company's findings at the time of its intervention only and within the limits of Client's instructions. It and the Company's sole responsibility is to its Client and the document does not constitute parties to a transaction from exercising their rights and obligations under the transaction documents. This document cannot be reproduced except in full, without prior written approval of the Company. Any unauthorized alteration, forgery or falsification of the content or appearance of this document is unlawful and offenders may be prosecuted to the fullest extent of the law. Unless otherwise stated the results shown in this test report refer only to the equipment tested and each equipment are related to 30 days only.

SGS Korea Co., Ltd.

 322, The O valley, 555-8, Hoggae-dong, Dongan-gu, Anyang-si, Gyeonggi-do, Korea 431-080
 T +82 (0)31 4808 000 F +82 (0)31 4808 059 <http://korea.sgs.com> or www.kr.sgs.com/greendat

FDS2 Version 5

Member of the SGS Group (Société Générale de Surveillance)

购买原装正品请认准-德方电子
 免费服务热线: 400-655-8700
 深圳总部电话: 0755-28187877
 网址: www.denovocn.com

Test Report No. F690101/LF-CTSAYAA13-31939

Issued Date: 2013. 07. 08 Page 3 of 6

Sample No. : AYAA13-31939.001
Sample Description : SAW FILTER
Item No./Part No. : N/A
Materials : N/A

Flame Retardants-PBBs/PBDEs

Test Items	Unit	Test Method	MDL	Results
Decabromodiphenyl ether	mg/kg	With reference to IEC 62321:2008, GC-MS	5	N.D.

Halogen Content

Test Items	Unit	Test Method	MDL	Results
Bromine(Br)	mg/kg	BS EN 14582:2007 , IC	30	N.D.
Chlorine(Cl)	mg/kg	BS EN 14582:2007 , IC	30	N.D.

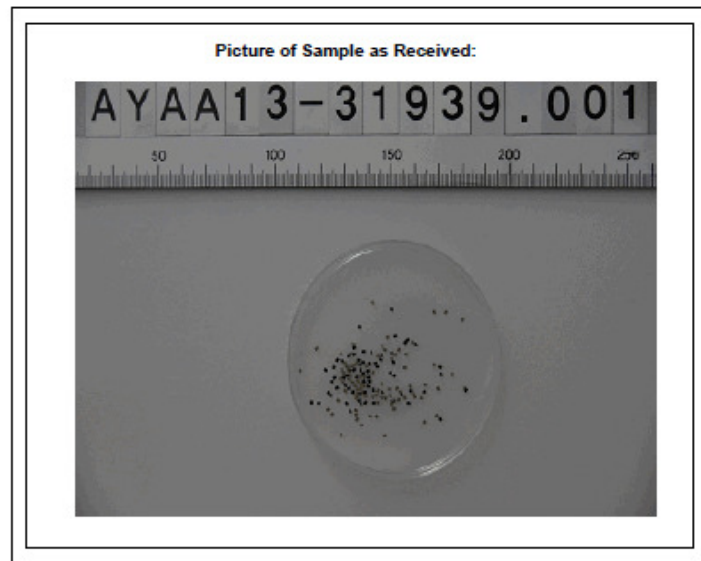
NOTE:

- (1) N.D. = Not detected.(<MDL)
- (2) mg/kg = ppm
- (3) MDL = Method Detection Limit
- (4) - = No regulation
- (5) Negative = Undetectable / Positive = Detectable
- (6) ** = Qualitative analysis (No Unit)
- (7) * = Boiling-water-extraction:
 Negative = Absence of CrVI coating
 Positive = Presence of CrVI coating; the detected concentration in boiling-water-extraction solution is equal or greater than 0.02 mg/kg with 50 cm² sample surface area.

This document is issued by the Company subject to its General Conditions of Service which are available on request or accessible at <http://www.sgs.com/DocumentConditions.pdf>, for electronic format documents, subject to Terms and Conditions for Electronic Documents at <http://www.sgs.com/DocumentConditions.pdf>. Attention is drawn to the limitation of liability, indemnification and jurisdiction clauses (where applicable) in force at the time of the intervention only and within the limits of Client's instructions, if any. The Company's sole responsibility is to its Client and this document does not constitute notice in a transaction from exercising of their rights and obligations under the transaction documents. This document cannot be reproduced except in full, without prior written approval of the Company. Any unauthorized alteration, forgery or falsification of the content or appearance of this document is unlawful and offenders may be prosecuted to the fullest extent of the law. Client's attention is drawn the results shown in this test report refer only to the sample(s) tested and each sample(s) are retained for 30 days only.

F052 Version5

SGS Korea Co.,Ltd.

 322, The O valley, 555-6, Hogeje-dong, Dongan-gu, Anyang-si, Gyeonggi-do, Korea 431-080
 t +82 (0)31 4608 000 f +82 (0)31 4608 050 <http://www.sgslab.co.kr> www.kr.sgs.com/greentab

购买原装正品请认准-德方电子
 免费服务热线: 400-655-8700
 深圳总部电话: 0755-28187877
 网址: www.denovocn.com



Test Report No. F690101/LF-CTSAYAA13-31939

Issued Date: 2013. 07. 08 Page 4 of 6

Testing Flow Chart for RoHS: Cd/Pb/Hg/Cr⁶⁺ /PBBs&PBDEs Testing

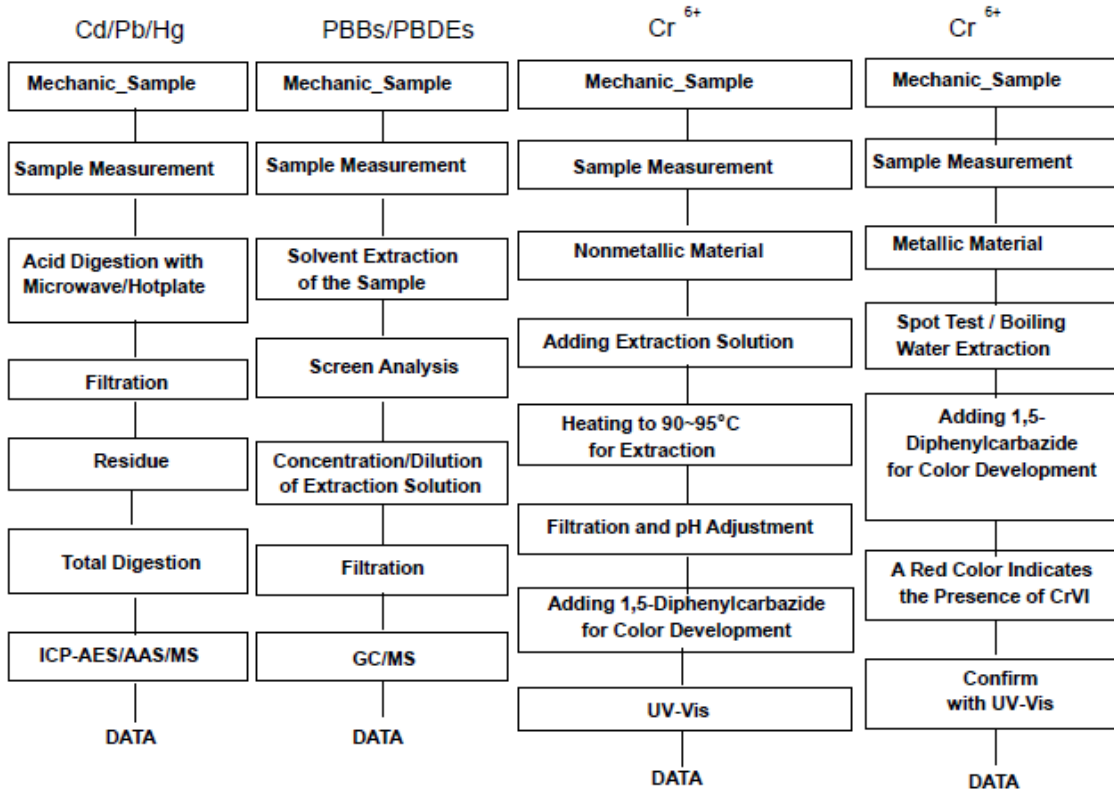

The samples were dissolved totally by pre-conditioning method according to above flow chart for Cd,Pb,Hg.
Section Chief : Gilsae Yi

NOTE:

- (1) N.D. = Not detected.(<MDL)
- (2) mg/kg = ppm
- (3) MDL = Method Detection Limit
- (4) - = No regulation
- (5) Negative = Undetectable / Positive = Detectable
- (6) ** = Qualitative analysis (No Unit)
- (7) * = Boiling-water-extraction:
Negative = Absence of CrVI coating
Positive = Presence of CrVI coating: the detected concentration in boiling-water-extraction solution is equal or greater than 0.02 mg/kg with 50 cm² sample surface area.

The document is issued by the Company subject to its General Conditions of Service printed hereafter, available on request or accessible at <http://www.sgs.com/ClientandConditions.aspx> for electronic format documents, subject to Terms and Conditions for Electronic Documents at <http://www.sgs.com/ClientandConditions.aspx>. Attention is drawn to the limitation of liability, indemnification and jurisdiction issues defined therein. Any holder of the document is advised that information contained therein reflects the Company's findings at the time of its intervention only and within the limits of Client's instructions, if any. The Company will not be responsible to its Client and the document does not constitute parties to a transaction from existing at the time and obligations under the transaction documents. This document cannot be reproduced except in full, without prior written approval of the Company. Any unauthorized alteration, forgery or falsification of the content or appearance of this document is illegal and offenders may be prosecuted to the fullest extent of the law.
Dates otherwise stated the results shown in this test report are only for the sample(s) tested and each sample(s) are retained for 90 days only.

F052 Version5

SGS Korea Co., Ltd.

322, The O valley, 555-8, Hoge-dong, Dongan-gu, Anyang-si, Gyeonggi-do, Korea 431-080
t +82 (0)31 4608 000 f +82 (0)31 4608 050 <http://www.sgskorea.com> www.kr.sgs.com/greenlab

Member of the SGS Group (Société Générale de Surveillance)

购买原装正品请认准-德方电子
免费服务热线: 400-655-8700
深圳总部电话: 0755-28187877
网址: www.denovocn.com



Test Report No. F690101/LF-CTSAYAA13-31939

Issued Date: 2013. 07. 08 Page 5 of 6

Flow Chart for Inorganic Elements Testing

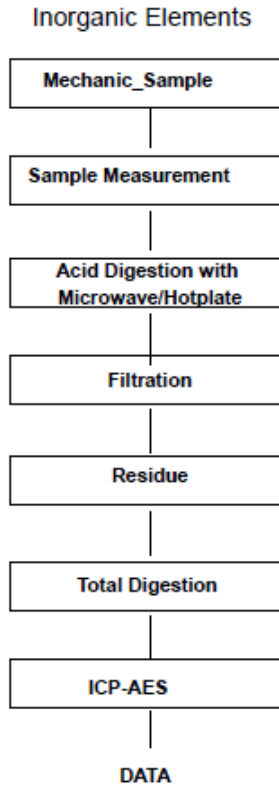

NOTE:

- (1) N.D. = Not detected. (<MDL)
- (2) mg/kg = ppm
- (3) MDL = Method Detection Limit
- (4) - = No regulation
- (5) Negative = Undetectable / Positive = Detectable
- (6) ** = Qualitative analysis (No Unit)
- (7) * = Boiling-water-extraction:
 Negative = Absence of CrVI coating
 Positive = Presence of CrVI coating; the detected concentration in boiling-water-extraction solution is equal or greater than 0.02 mg/kg with 50 cm² sample surface area.

* Document is issued by the Company subject to its General Conditions of Service printed on each order or report or available at <http://www.sgs.com/Products/Services/GeneralConditions.htm>, for electronic format documents, subject to Terms and Conditions for Electronic Documents at <http://www.sgs.com/Products/Services/GeneralConditions.htm>. Selection is given to the location of facility, administration and jurisdiction issues (where defined). Any holder of this document is advised that information contained herein reflects the Company's findings at the time of its intervention only and within the limits of Client's instructions. If the Company's work responsibility is to be Client and the document does not accurately reflect a transaction from exceeding all their rights and obligations under the transaction documents. This document cannot be reproduced except in full, without prior written approval of the Company. Any unauthorized alteration, copy or modification of the content or appearance of this document is prohibited and therefore may be prosecuted to the fullest extent of the law. See also service sheet the results shown in this test report refer only to the sample(s) tested and each sample(s) are retained for 30 days only.

购买原装正品请认准-德方电子
 免费服务热线: 400-655-8700
 深圳总部电话: 0755-28187877
 网址: www.denovocn.com



Test Report No. F690101/LF-CTSAYAA13-31939

Issued Date: 2013. 07. 08 Page 6 of 6

Flow Chart for Halogen Test

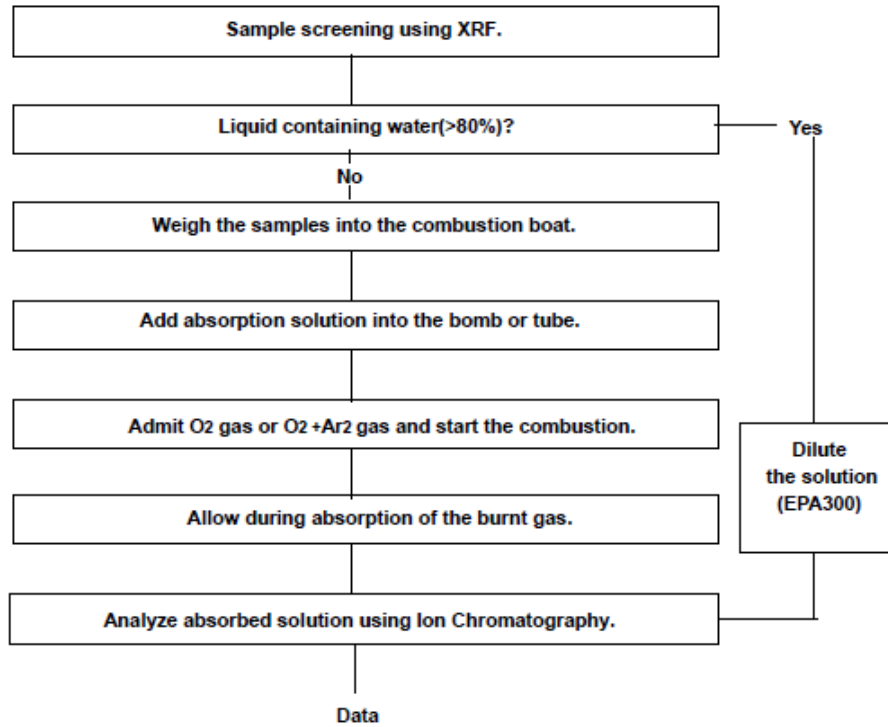

*** End ***

NOTE:

- (1) N.D. = Not detected.(<MDL)
- (2) mg/kg = ppm
- (3) MDL = Method Detection Limit
- (4) - = No regulation
- (5) Negative = Undetectable / Positive = Detectable
- (6) ** = Qualitative analysis (No Unit)
- (7) * = Boiling-water-extraction:
 Negative = Absence of CrVI coating
 Positive = Presence of CrVI coating; the detected concentration in boiling-water-extraction solution is equal or greater than 0.02 mg/kg with 50 cm² sample surface area.

This document is issued by the Company subject to the General Conditions of Service printed on the reverse side or available at http://www.sgs.com/conditions_of_service.pdf, for electronic format documents, subject to Terms and Conditions for Electronic Documents at http://www.sgs.com/conditions_of_service_electronic.pdf. Attention is drawn to the limitation of liability, indemnification and jurisdiction clauses defined therein. Any holder of the document is advised that information contained therein reflects the Company's findings at the time of its issuance only and within the limits of Client's instructions. It is the Company's sole responsibility as to its Client and the document does not constitute parties to a transaction from assuming of their rights and obligations under the transaction documents. This document cannot be reproduced except in full, without prior written approval of the Company. Any unauthorized alteration, copy or modification of the content or appearance of this document is unlawful and therefore may be prosecuted to the fullest extent of the law. (Data obtained stated the results shown in the test report refer only to the samples tested and such samples) are retained for 30 days only.

SGS Korea Co., Ltd.

322, The O valley, 555-6, Hoggae-dong, Dongan-gu, Anyang-si, Gyeonggi-do, Korea 431-080
 t +82 (0)31 4608 000 f +82 (0)31 4608 059 <http://www.sgs.com> www.kr.sgs.com/greentab

F052 Version5

Member of the SGS Group (Société Générale de Surveillance)

购买原装正品请认准-德方电子
 免费服务热线: 400-655-8700
 深圳总部电话: 0755-28187877
 网址: www.denovocn.com